

SAFELINE VARIO

MANUAL

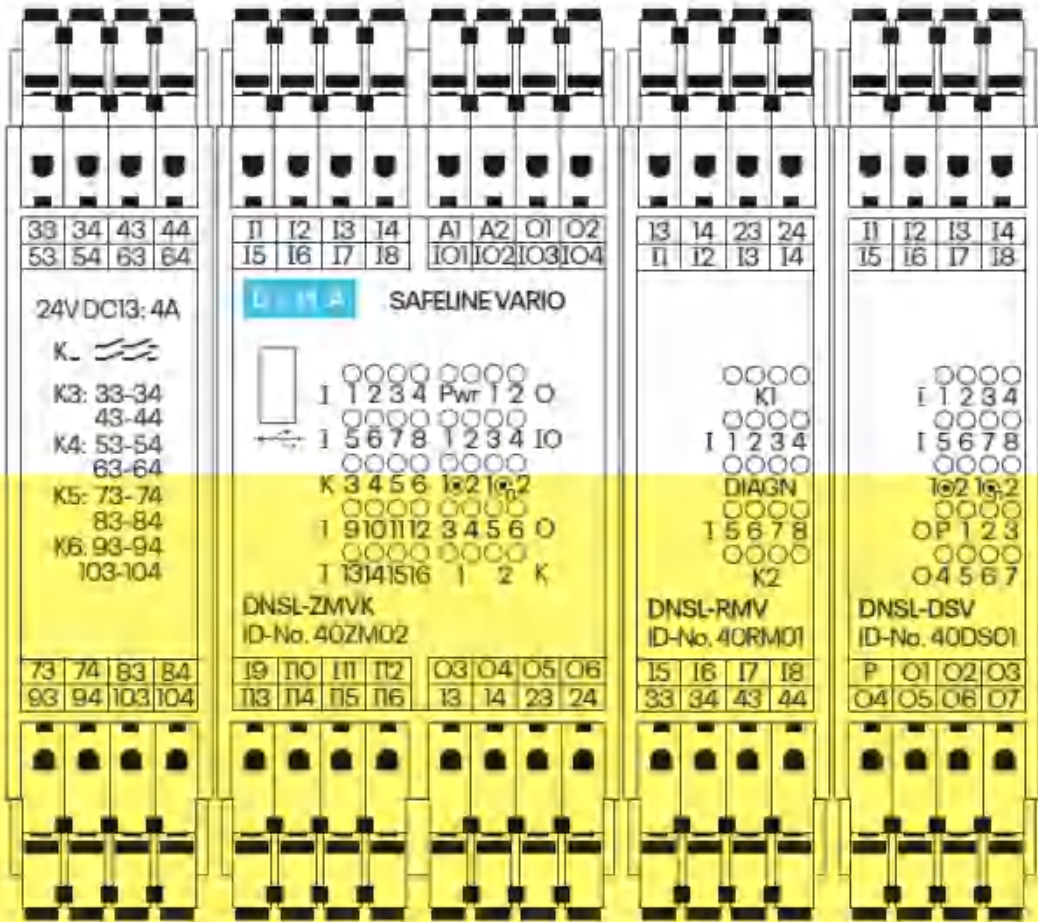

multi-functional safety system

DINA Elektronik GmbH

Esslinger Straße 84
72649 Wolfschlugen
Germany

Phone +49 (0) 7022 9517 0

E-mail info@dina.de

Web www.dina.de

© Copyright by DINA Elektronik GmbH 2023

All parts of this documentation are protected by copyright.

Any use beyond that permitted under copyright law is not permitted without express written consent from the publisher. This applies in particular to the reproduction, distribution and translation of this documentation or parts thereof, as well as the storage and processing of this content using electronic data processing systems.

The information contained in this documentation corresponds to the technical state of the product at the time these operating instructions were published.

This manual is valid for the following SAFELINE VARIO modules:

Central module	Speed monitoring module	In-/Output module	Fieldbus module	Network module	Cascade module
DNSL-ZMV	DNSL-DRV	DNSL- INV	DNSL-COV	DNSL-NIV	DNSL-CMV
DNSL-ZMVK	DNSL-DSV	DNSL-IOV	DNSL-DPV	DNSL-NRV	
DNSL-ZMVD	DNSL-SIV	DNSL-RMV	DNSL-ECV		
	DNSL-BIV		DNSL-EPV		
			DNSL-MOV		
			DNSL-PLV		
			DNSL-PNV		

Legal information

Handbook: Manual
Target group: Electricians, electrical designers
Editor: DINA Elektronik GmbH
File name: BA_slvario_en_v01_0123.docx
Language: ENG
Publication as at: 25. October 2023

Table of Contents

1	Structure of the document	1
1.1	Conventions.....	1
1.1.1	Emphasizing information	1
1.1.2	Emphasizing paragraphs using typography	1
1.1.3	Emphasizing words using typography	1
1.2	Your opinion is important to us!.....	2
2	Safety.....	3
2.1	Warnings	3
2.1.1	Function of warnings	3
2.1.2	Design of warnings.....	3
2.1.3	Hazard symbols.....	4
2.2	Qualification of personnel	4
2.2.1	Electrician.....	4
2.2.2	Electrical designers	4
2.3	Intended use and improper use	5
2.3.1	Certification data	5
2.4	Documentation	6
2.5	Safety regulations.....	6
2.5.1	Retrofitting and conversion.....	7
2.5.2	Basic safety regulations.....	7
2.6	Working on live parts	8
3	EC declaration of conformity	9
4	SAFELINE VARIO modules	10
4.1	Overview	10
4.2	Product description	11
4.2.1	SL VARIO-Designer	12
4.2.3	Application examples	14
4.2.4	Construction	14
4.2.5	Terminals	14
5	Central modules.....	14
5.1	Product description.....	14

5.2	Overview	15
5.2.1	DNSL-ZMV pin assignment	16
5.2.2	DNSL-ZMVK pin assignment.....	17
5.2.3	DNSL-ZMVD pin assignment.....	18
5.2.4	DNSL-ZMV block diagrams and expansions	19
5.2.4.1	DNSL-ZMV block diagram	19
5.2.4.2	DNSL-ZMVK block diagram (expansion)	20
5.2.4.3	DNSL-ZMVD block diagram (DS1 expansion)	20
5.2.4.4	DNSL-ZMVD block diagram (DS2 expansion)	21
6	Function modules.....	22
6.1	Product description	22
6.2	Input/output modules	22
6.2.1	DNSL-IOV pin assignment	23
6.2.1.1	Block diagram	23
6.2.2	DNSL-INV pin assignment.....	24
6.2.2.1	Block diagram	24
6.2.3	DNSL-RMV pin assignment.....	25
6.2.3.1	Block diagram	25
6.3	Speed monitoring modules	26
6.3.1	DNSL-DSV and DRV, BIV pin assignment	27
6.3.1.1	Block diagram	27
6.3.2	DNSL-SIV pin assignment.....	28
6.3.2.1	Block diagram	29
6.4	Fieldbus modules.....	30
6.4.1	DNSL-EPV/DPV pin assignment	30
6.4.1.1	DNSL-COV/DPV block diagram, 8-pin.....	31
6.4.1.2	DNSL-COV/DPV block diagram, 10-pin.....	31
6.4.1.3	DNSL-ECV/EPV/MOV/PLV/PNV block diagram, 8-pin	32
6.4.1.4	DNSL-ECV/EPV/MOV/PLV/PNV block diagram, 10-pin	32
6.5	DNSL-CMV cascade module	33
6.5.1	Structure of a cascade.....	33
6.5.2	DNSL-CMV pin assignment.....	34
6.5.2.1	Block diagram	35
6.5.3	Cascade addressing.....	36

6.6	DNSL-NIV/NRV network module	37
6.6.1	DNSL-NIV pin assignment.....	38
6.6.1.1	Block diagram	38
6.6.2	DNSL-NRV pin assignment	39
6.6.2.1	Block diagram	39
7	Safety functions.....	40
7.1	Safety circuits	40
7.1.2	Inputs for safety circuits with acknowledgment	41
7.1.3	Inputs for safety circuits with external acknowledgment input	42
7.2	Two-handed monitoring	42
7.3	Inputs for safety mats, switching strips and bumpers on the central module	43
8	Standstill and speed monitoring	44
8.1.1	Features of rotation monitoring.....	44
8.1.1.1	Requirements for the incremental encoder	45
8.1.1.2	Requirements for the proximity switch	45
8.1.1.3	Overview of measurement systems.....	46
8.1.1.4	Connection options at the measurement inputs on the DNSL-ZMV	47
8.1.1.5	DNCO functions	48
9	Diagnostics and switching status displays	49
9.1	LED indicators	49
9.2	Diagnostics LEDs	51
11	Technical data.....	53
11.1	Supply	53
11.2	Inputs.....	53
11.3	Semiconductor outputs	55
11.4	Contact outputs	56
11.6	Connection data	57
11.7	Environmental conditions.....	57
11.8	Dimensions.....	57
11.9	Safety-related parameters acc. to DIN EN ISO 13849-1:2016-06	59
11.10	Contact service life	60
12	Installation and removal.....	65
12.1	Installing a module.....	65
12.1.1	Overview	65

12.2 Removing a module..... 65

1 Structure of the document

1.1 Conventions

Information of particular importance is emphasized in this documentation through the use of symbols, typography or formulations.

1.1.1 Emphasizing information

The following symbols indicate important information:



Degree of hazard (e.g. WARNING): Triangular symbols indicate the degree of hazard in warnings.



Type of hazard (e.g. electrical shock – dangerous voltage): Triangular symbols indicate the type of hazard in warnings.



Information: Additional clarification.



Tip: Additional information to help optimize the workflow.

1.1.2 Emphasizing paragraphs using typography

The following typography is used to emphasize paragraphs with special functions:



Indicates an instruction.



Indicates an expected reaction.



Indicates an unexpected reaction.



Indicates an item in a list.

1.1.3 Emphasizing words using typography

The following typography is used to emphasize words with special functions:

(1)

Represents a numbered item in a figure.



Indicates a cross-reference to another page, figure or document.

1.2 Your opinion is important to us!

We do all we can to provide complete, accurate documentation for the product. If you have any suggestions for improvement or advice for us, please share your thoughts with us. Send us your comments by e-mail to the following address.

E-mail: info@dina.de

2 Safety

2.1 Warnings

2.1.1 Function of warnings

Warnings warn users about hazards when handling the product. The hazards are classified, specified, described and supplemented with information about how to avoid them.

- If there is a warning before a list of instructions, the hazard is present throughout the entire activity.
- If there is a warning immediately before an instruction, the hazard is present during the next step.

2.1.2 Design of warnings

All warnings are indicated by a signal word and a warning symbol. The different combinations of the signal word and warning symbol indicate the degree of danger.



DANGER

For an immediate hazard that will result in severe injuries or death.



WARNING

For an immediate hazard that could result in severe injuries or death.



CAUTION

For a potentially hazardous situation that could result in injuries.



CAUTION

For a potentially harmful situation in which the product or an item near it could be damaged.



CAUTION

For a hazard that could cause environmental damage.

2.1.3 Hazard symbols

**Note**

The warning symbol may be present alongside another hazard symbol that represents the type of hazard, in order to attract the reader's attention.

Hazard symbols are indicated by a triangular symbol in the context of warnings. The following hazard symbols are used in this documentation:



Electric shock – dangerous voltage!

2.2 Qualification of personnel

DINA Elektronik GmbH distinguishes between specialist staff with different qualifications when it comes to carrying out work on the product. The minimum required qualifications are specified for each task and are defined as follows:

2.2.1 Electrician

Specialist who installs, maintains and repairs the electrical system in the product. A specialist is a person whose specialist training means that they have the knowledge and experience, including knowledge of relevant regulations, necessary to assess the work assigned to them and the potential hazards.

**Note**

When evaluating a person's specialist training, multiple years of work in the relevant field may also be taken into account.

→ **DIN VDE 1000-10** Requirements for persons working in a field of electrical engineering.

2.2.2 Electrical designers

Specialists who design the electrical system and the product. A specialist is a person whose specialist training means that they have the knowledge and experience, including knowledge of relevant regulations, necessary to assess the work assigned to them and the potential hazards.

**Note**

When evaluating a person's specialist training, multiple years of work in the relevant field may also be taken into account.

→ **DIN VDE 1000-10** Requirements for persons working in a field of electrical engineering.

2.3 Intended use and improper use

The product has exclusively been developed for use for the purpose described here. The specifications set out in these operating instructions must be strictly complied with.

- **SAFELINE VARIO** is a multi-functional, modular, configurable safety system.
- The safety system is intended for use on machines and plants to prevent hazards from arising.
- It monitors protective equipment and records/monitors standstill and speeds of electric drives.

Any other form of use is regarded as improper use.

If the product is

- not used as intended,
- improperly maintained or
- incorrectly operated,

the manufacturer will not assume any liability for any damage that results. In this case, the risk shall be borne exclusively by the user.

2.3.1 Certification data

The product is certified as safety equipment in accordance with:

<ul style="list-style-type: none"> ▪ DIN EN ISO 13849-1:2016-06, Category 4, PLe 	
<ul style="list-style-type: none"> ▪ DGUV Test: GS-ET-20:2016-10 ▪ EC type examination certificate 	Notified body: DGUV Test Prüf- und Zertifizierungsstelle, Elektrotechnik, Fachbereich: ETEM Gustav-Heinemann-Ufer 130 50968 Cologne, Germany (Reg. no.: 0340)
<ul style="list-style-type: none"> ▪ EMC Directive 	Certified by: ELMAC GmbH Bondorf
<ul style="list-style-type: none"> ▪ CNL, USL 	File E227037
<ul style="list-style-type: none"> ▪ QA system certified as per DIN EN ISO 9001:2015 	Certified by: DQS GmbH, 60433 Frankfurt am Main, Germany

**Note**

You can download the certificates from our website:

→ <https://www.dina.de/downloads>

2.4 Documentation

Documentation contain instructions on how to use a product safely, correctly and cost-effectively. Follow the instructions in these document in order to prevent hazards, avoid repair costs and standstill, and improve the reliability and service life of the product. You must read the operating instructions and ensure that you understand them.



- ▶ Before working with the product, read the operating instructions that come with the product.

- SAFELINE VARIO manual
- SAFELINE VARIO Designer manual
- SAFELINE VARIO Diagnostics manual

You can find them at www.dina.de/downloads.

- ▶ Always ensure that the operating instructions are available where the product is in use.
-

2.5 Safety regulations

The safety regulations listed below must always be complied with. In the event that these safety regulations are not complied with or the device is used improperly, **DINA Elektronik GmbH** accepts no liability for any resulting injury or damage.

- The product must only be installed and commissioned by a skilled electrician or a trained, instructed person, who is familiar with these operating instructions and the applicable specifications regarding occupational health and safety and accident prevention.
-

**WARNING**

Danger to persons and materials! In the event that specifications are not complied with, this can result in death, severe injuries or significant material damage.

- ▶ Observe VDE, EN and local regulations, in particular with regard to protective measures.
-

- If the emergency stop is used, either the integrated restart prevention function must be used or the machine must be prevented from restarting automatically using a superordinate control system.
 - When installing the device, the required distances as per DIN EN 50274, VDE 0660514 must be taken into account.
 - ▶ During transport, storage and operation, comply with the conditions set out in EN 60068-2-1, 2-2.
-

- ▶ Assemble the device in a control cabinet with at least IP54 degree of protection. Otherwise, dust and moisture can impair the functions. The device must be installed in a control cabinet.
 - ▶ Ensure that the output contacts have sufficient protective circuitry for capacitive and inductive loads.
 - ▶ Follow the specifications in the general technical data.
-



Note

More detailed information can be found in the → **Technical data** section.



WARNING

Electric shock – dangerous voltage! During operation, switching devices conduct dangerous voltages.



- ▶ Never remove protective covers from electrical switching devices during operation.
-

- ▶ Replace the device the first time a fault occurs.
-



- ▶ Dispose of the device in accordance with nationally applicable environmental regulations.
-

2.5.1 Retrofitting and conversion

- Unauthorized conversion voids any warranty. This can cause hazards that can lead to severe or even fatal injury.

2.5.2 Basic safety regulations

The safety regulations listed below must always be complied with. In the event that these safety regulations are not complied with or the device is used improperly, **DINA Elektronik GmbH** accepts no liability for any resulting injury or damage.

- The product described here has been developed to perform safety-related functions as part of an entire system.
- The entire system is made up of sensors, analysis units, reporting units and safe switch-off concepts.
- It is the responsibility of the manufacturer of a system or machine to validate the correct overall function.
- The manufacturer of the system is obligated to check and document the efficacy of the implemented safety concept within the entire system. This documentation must be produced again every time the safety concept or safety parameters are modified.

- The manufacturer's specifications for the system or machine with regard to maintenance intervals must be complied with.
- **DINA Elektronik GmbH** is not able to make any guarantees regarding the properties of an overall system not designed by the company.
- **DINA Elektronik GmbH** accepts no liability for any recommendations given or implied in the following description.
- No new guarantee, warranty or liability claims that go beyond **DINA Elektronik GmbH's** general delivery conditions can be derived from the following description.
- To prevent EMC disturbances, the physical environmental and operating conditions where the product is installed must correspond to the EMC section of DIN EN 602041.
- If contact outputs are used, the safety function must be requested at least once per month for Performance Level (e) and once per year for Performance Level (d).

2.6 Working on live parts

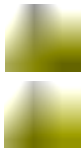

WARNING

Electric shock – dangerous voltage! Touching live components can cause severe or even fatal injury, depending on circumstances, as a result of an electric shock.

- ▶ Never assume that a circuit is dead.
 - ▶ Always check circuits as a safety precaution! Components being worked on may only be live if this is absolutely necessary and stipulated.
 - ▶ Accident prevention regulations (e.g. VBG4 and VDE 105) must be observed during all work.
 - ▶ Only use suitable, intact tools and measuring equipment.
-

3 EC declaration of conformity



Original EG-Konformitätserklärung

(gemäß der Richtlinie 2006/42/EG, Anhang II, 1A)

Original EC-Declaration of Conformity

(according to Directive 2006/42 / EC, Annex II, 1A)

DINA Elektronik GmbH
Esslinger Str. 84
72649 Wolfschlugen
Deutschland

Wir erklären, dass das folgende Produkt allen einschlägigen Bestimmungen der Richtlinie 2006/42/EG entspricht.

We declare, that the following product fulfils all the relevant provisions of Directive 2006/42 / EC.

Produkt/Product	Funktion/Function
SAFELINE VARIO Sicherheitsschaltgeräte/Safety devices DNSL-ZMV, -ZMVK, -ZMVD, -ZMVA DNSL-DSV, -DRV, -SIV, -BIV, -INV, -IOV, - RMV, -CMV, -NIV, -NRV, -COV, -DPV, -ECV, - EPC, -MOV, -PLV, -PNV	Multifunktionales, modulares, konfigurierbares Sicherheitssystem Multifunctional, modulare, configurable safety system

Weitere EU-Richtlinien/ Further EC- directives

2014/30/EU EMV-Richtlinie/EMC-Directive
2011/65/EU RoHS Richtlinie/RoHS-Directive

Benannte Stelle/Notified Body

DGUV Test
Prüf- und Zertifizierungsstelle,
Elektrotechnik
Fachbereich Energie Textil
Elektro Medienerzeugnisse
Gustav-Heinemann-Ufer 130
D-50968 Köln

(Kenn-Nr. 0340)

EG Baumusterprüfbescheinigung/EC Type- Examination certificate

Reg.-Nr./No.: ET 22053

Bevollmächtigter für die Zusammenstellung der technischen Unterlagen/Authorized representative for the compilation of the technical documents.

DINA Elektronik GmbH
Esslinger Str. 84
72649 Wolfschlugen
Deutschland

Wolfschlugen, 05.08.2022



Markus Henzler
Entwicklung/development

4 SAFELINE VARIO modules

4.1 Overview

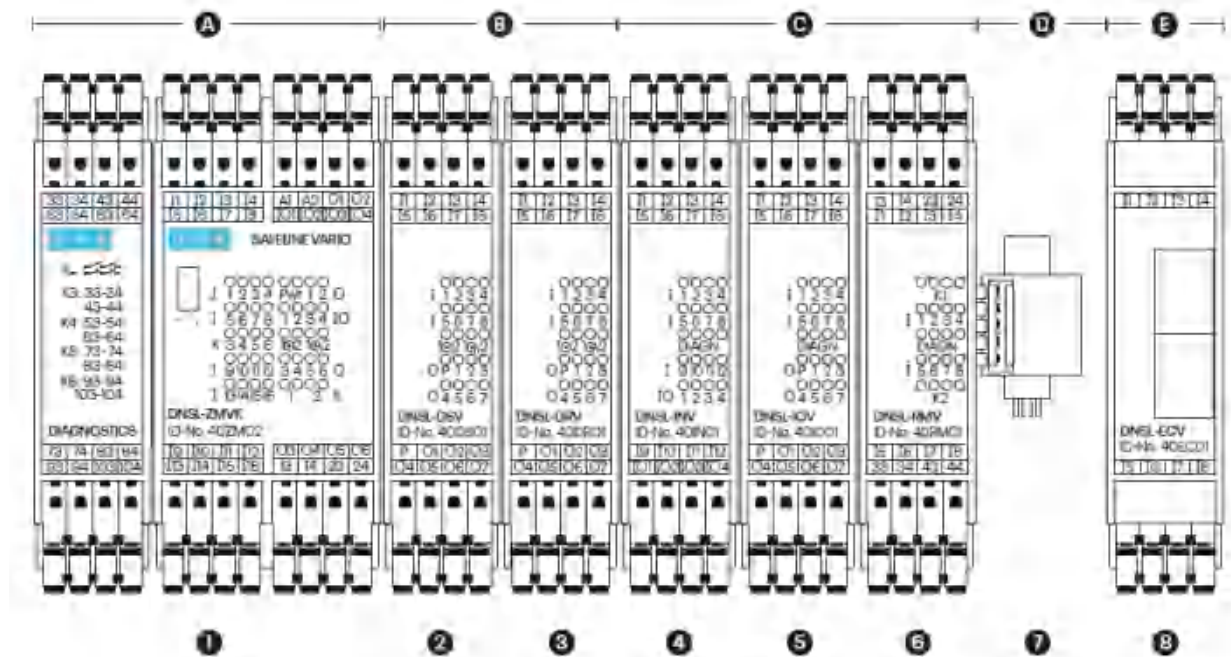

- | | | | |
|------------|-----------------------------|------------|-------------------------|
| (A) | Central module | (B) | Speed monitoring |
| (1) | DNSL-ZMVK | (2) | DNSL-DSV |
| | | (3) | DNSL-DRV |
| (C) | Input/output modules | (D) | Additional |
| (4) | DNSL-INV | (7) | Bus |
| (5) | DNSL-IOV | | |
| (6) | DNSL-RMV | | |
| (E) | Fieldbus module | | |
| (8) | DNSL-ECV | | |

4.2 Product description

- **SAFELINE VARIO** is a multi-functional, modular, configurable safety system.
- The safety system is intended for use on machines and plants to prevent hazards from arising.
- The safety system consists of a central module and various function modules and fieldbus modules.
- A range of safe digital and analog inputs, semiconductor outputs and contact outputs are available.
- The status of the inputs and outputs, the operating voltage and other diagnostic functions are indicated by LEDs.
- The modules can be parameterized using the **SL VARIO-Designer** graphical programming software.
- A storage medium is integrated in the central module. This contains the parameterization software and the operating instructions. The safety application can be transferred via the USB interface and saved in the storage.
- The central module can be supplied in three housing sizes, depending on the functionality.

Technical data	
Housing 1 for central module	45.0 mm (1.772 in)
Housing 2 for central module	67.5 mm (2.657 in)
Housing 3 for central module	90.0 mm (3.543 in)
Housing size for all additional modules	22.5 mm (0.886 in)

- The modules are constructed on a DIN rail.

Technical data	
Size of DIN rail	35.0 mm (1.378 in)
Number of modules for one application	≤ 15

- The modules are connected to one another via bus connectors on the rail side.
- Potential overvoltages and overcurrents are monitored.



Note













For voltages ≥ 30 V or if there is a wire break at terminal **(A2)**, terminals **(A1)** and **(P)** are switched off internally.







- The semiconductor outputs are protected against overload and short circuiting.

4.2.1 SL VARIO-Designer

The **SL VARIO-Designer** graphical programming software enables a safety-related project for the **SAFELINE VARIO** product range to be created. A comprehensive library of standard and safety components are available to the user. As a result, both the inputs and outputs on the **SAFELINE VARIO modules** can be linked to one another in an application-specific manner, and safety-related functions such as emergency stops and speed monitoring can be implemented. Parameter tables enable a high level of flexibility. The graphical simulation reconstructs the created application on the PC. This simplifies the analysis and troubleshooting steps. The project is transferred via the USB interface on the central module. Subsequently, there are a range of comprehensive online diagnostics tools available.

See the extract from the **SL VARIO-Designer** handbook below:

Symbol	Function	Available quantity	Symbol	Function	Available quantity
	Operating mode selection switch	2		Two-man operation	2
	Safe brake test	8		Zone monitoring	16
	Active optoelectronic protective devices	2		Power control	1
	Area scanner	2		Synchronous comparator	1
	Cam	64		Binary coder/decoder	2 each
	Door element	16		Current monitoring	2

Symbol	Function	Available quantity	Symbol	Function	Available quantity
	Adder	8		Analog input comparator	4
	Subtractor	4		Analog step switch	4
	Copier	4		Threshold switch	2

4.2.3 Application examples

A list of potential application examples for the **SAFELINE VARIO** modules is provided below:

- Metalworking machines
- Woodworking machines
- Filling systems
- Packaging machines
- Escalators
- Elevators
- Platform technology
- Driverless transport systems
- etc.

4.2.4 Construction

The central module is positioned on the left. All other modules are always arranged in a row to the right of the central module. A central module is required for an application. The number of function modules needed depends on the requirements. The RJ45 sockets on the measurement systems for speed monitoring and the communication interface for the network and cascade module are located on the top of the module when installed. For DNSL-ZMVD and DNSL-NRV, the RJ45 sockets are also positioned on the bottom of the module. These must only be used for the specified functions. The connection cable for these can be inserted directly into the cable duct in the control cabinet. The connection sockets for the fieldbus connection are attached at the front.

4.2.5 Terminals

The modules are fitted with single terminals as standard.

All modules are available with double terminals.

5 Central modules

5.1 Product description

The central module is the base device and, depending on the device type, is equipped with:

- Inputs
- Relay outputs
- Safe semiconductor outputs
- Analog inputs
- Connections for movement monitoring
- USB interface

- Micro-SD memory card

The central module can be used alone or expanded using up to 14 function modules. The user-specific application is created using **SL VARIO-Designer**.

Central modules are available in a range of expansion levels.

5.2 Overview



	DNSL-ZMV	DNSL-ZMVK	DNSL-ZMVD
Safe digital inputs	16	16	32/48
Analog inputs*	8	8	8
Safe semiconductor outputs	6	6	6
Configurable inputs/outputs	4	4	4
Relay outputs	2	6	2
Encoder inputs	2	2	4/8
Measurement system	HTL	HTL	sin/cos, TTL
*) Inputs I1 to I18 can be configured as both digital and analog inputs.			

5.2.1 DNSL-ZMV pin assignment



	I1 to I8	Configurable as <ul style="list-style-type: none"> digital inputs or <ul style="list-style-type: none"> analog inputs
	I9 to I16	Configurable as <ul style="list-style-type: none"> digital inputs or <ul style="list-style-type: none"> Inputs for recording movement via initiators or HTL measurement systems.
	IO1 to IO4	Configurable as <ul style="list-style-type: none"> input or <ul style="list-style-type: none"> output
	A1	Operating voltage +24 V DC
	A2	Operating voltage 0 V
	O1 to O6	Semiconductor outputs
	13-14/23-24	Relay outputs K1, K2
	USB port	Mini USB for connection to the PC
	PWR LED	Operational readiness display
	LED I1 to I16	Inputs status display
	LED O1 to O6	Outputs status display
	LED IO1 to IO4	Inputs/outputs status display
	LED K1 to K2	Relay outputs status display
	LED	standstill monitoring status display
LED	Speed monitoring status display	

5.2.2 DNSL-ZMVK pin assignment

	I1 to I8	Configurable as <ul style="list-style-type: none"> digital inputs or <ul style="list-style-type: none"> analog inputs
	I9 to I16	Configurable as <ul style="list-style-type: none"> digital inputs or <ul style="list-style-type: none"> Inputs for recording movement via initiators or HTL measurement systems.
	IO1 to IO4	Configurable as <ul style="list-style-type: none"> input or <ul style="list-style-type: none"> output
	A1	Operating voltage +24 V DC
	A2	Operating voltage 0 V
	O1 to O6	Semiconductor outputs
	13-14, 23-24	Relay outputs K1, K2
	33-34/43-44	Relay output K3
	53-54/63-64	Relay output K4
	73-74/83-84	Relay output K5
93-94/103-104	Relay output K6	
USB port	Mini USB for connection to the PC	
PWR LED	Operational readiness display	
LED I1 to I16	Inputs status display	
LED O1 to O6	Outputs status display	
LED IO1 to IO4	Inputs/outputs status display	
LED K1 to K6	Relay outputs status display	

	LED 	standstill monitoring status display
	LED 	Speed monitoring status display

5.2.3 DNSL-ZMVD pin assignment

	I1 to I8	Configurable as <ul style="list-style-type: none"> digital inputs or <ul style="list-style-type: none"> analog inputs
	I9 to I48	Configurable as <ul style="list-style-type: none"> digital inputs
	IO1 to IO4	Configurable as <ul style="list-style-type: none"> input or <ul style="list-style-type: none"> output
	RJ45 socket 1 to 8	Encoder interface
	A1	Operating voltage +24 V DC
	A2	Operating voltage 0 V
	O1 to O6	Semiconductor outputs
	13-14/23-24	Relay outputs K1, K2
	USB port	Mini USB for connection to the PC
	PWR LED	Operational readiness display
	LED I1 to I48	Inputs status display
	LED O1 to O6	Outputs status display
	LED IO1 to IO4	Inputs/outputs status display
	LED K1 to K2	Relay outputs status display
	LED 	standstill monitoring status display



The ZMVD can be operated with one (DS1) or two (DS1 and DS2) expansion modules.

5.2.4 DNSL-ZMV block diagrams and expansions

5.2.4.1 DNSL-ZMV block diagram

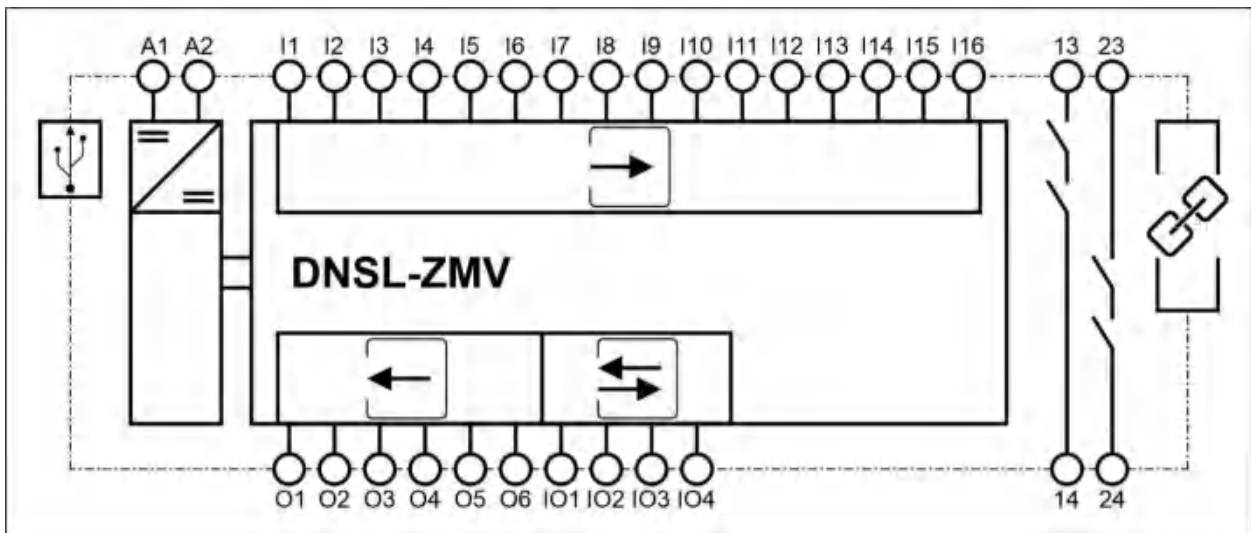

Inputs



Outputs



Configurable inputs/outputs



Expansion modules interface



USB

5.2.4.2 DNSL-ZMVK block diagram (expansion)

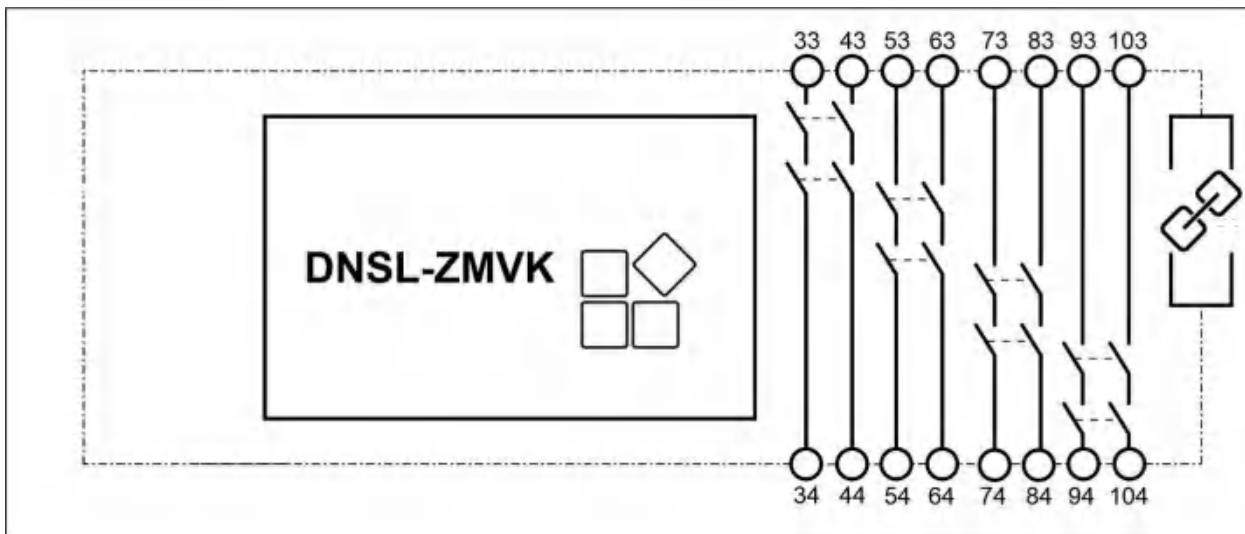

Expansion



Expansion modules interface

5.2.4.3 DNSL-ZMVD block diagram (DS1 expansion)

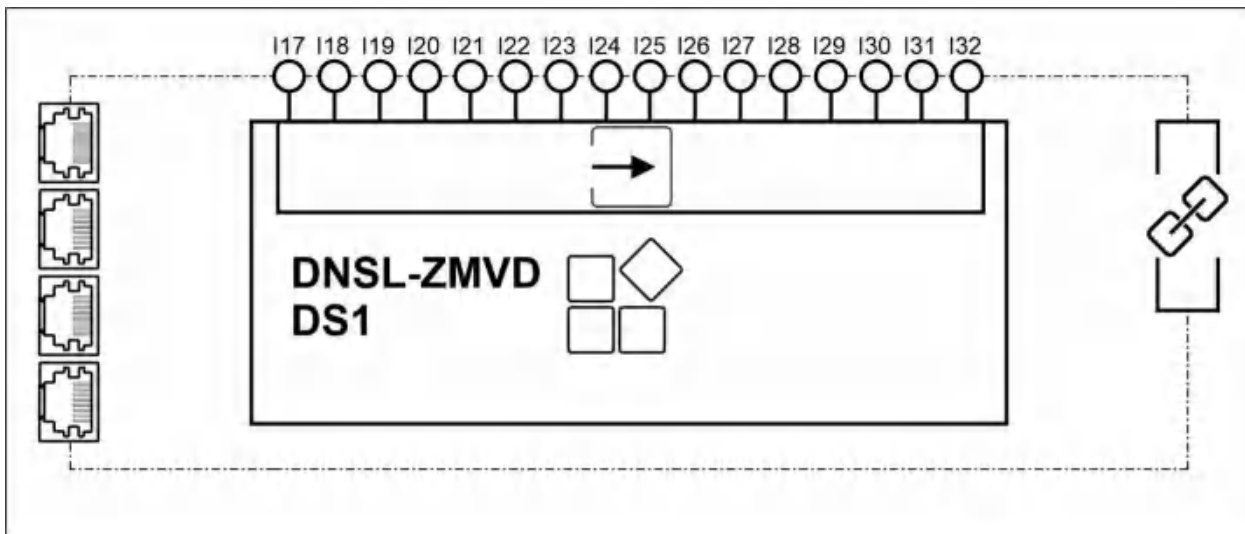

Expansion



Expansion modules interface



RJ45 socket



Inputs

5.2.4.4 DNSL-ZMVD block diagram (DS2 expansion)

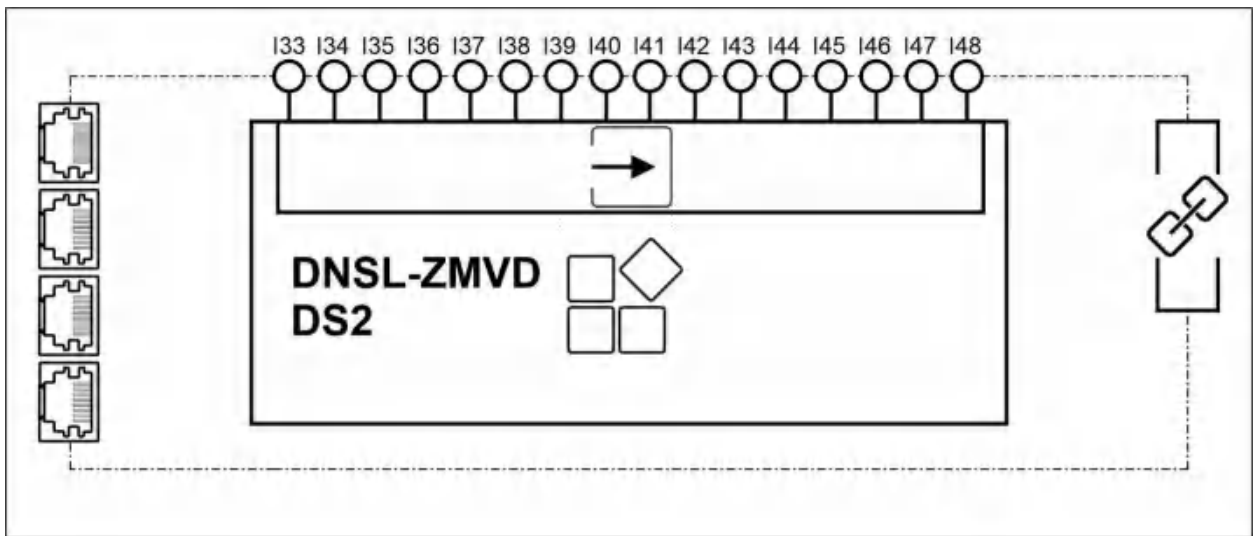

Expansion



Expansion modules interface



RJ45 socket



Inputs

6 Function modules

6.1 Product description

A range of function modules are available to expand the functionality. All modules are connected to each other using T-bus connectors and mounted on a 35 mm DIN rail.

The following function modules are available:

- Input/output modules
- Standstill and speed monitoring modules
- Fieldbus modules
- Cascade module
- Network module

6.2 Input/output modules

Both the number of inputs and outputs, and the number of safety circuits (emergency stop, safety doors, two-hand, etc.) can be increased by using this expansion module.

The following input/output modules are available:

	DNSL-IOV	DNSL-INV	DNSL-RMV
Safe digital inputs	8	12	8
Analog inputs	-/-	-/-	-/-
Safe semiconductor outputs	7	-/-	-/-
Configurable inputs/outputs	-/-	4	-/-
Relay outputs	-/-	-/-	2

6.2.1 DNSL-IOV pin assignment

	I1 to I8	digital inputs
	P	Operating voltage +24 V DC
	O1 to O7	Semiconductor outputs
	LED P	Status of the supply voltage of the semiconductor outputs
	LED I1 to I8	Inputs status display
	LED O1 to O7	Outputs status display
	DIAGN	Diagnostics display

6.2.1.1 Block diagram

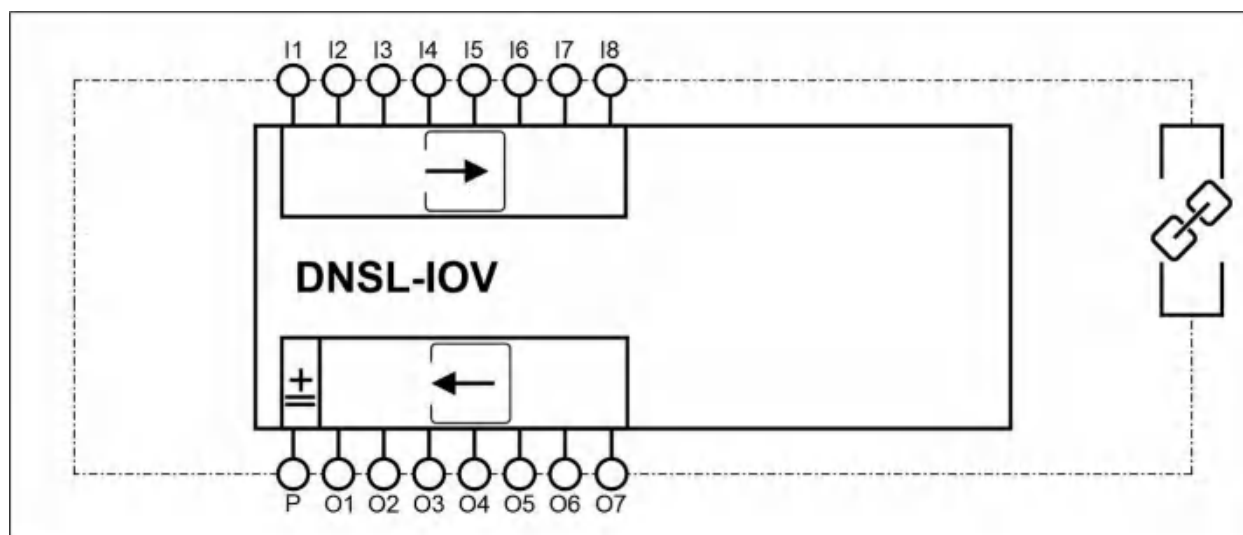

Inputs



Outputs



+24 V DC



Expansion modules interface

6.2.2 DNSL-INV pin assignment

<p> I1 I2 I3 I4 I5 I6 I7 I8 I 1 2 3 4 I 5 6 7 8 DIAGN I 9 10 11 12 IO 1 2 3 4 DNSL-INV ID-No. 40INO1 I9 I10 I11 I12 IO1 IO2 IO3 IO4 </p>	I1 to I12	digital inputs
	IO1 to IO4	Configurable as <ul style="list-style-type: none"> ▪ input or <ul style="list-style-type: none"> ▪ output
	LED I1 to I12	Inputs status display
	LED IO1 to IO4	Inputs/outputs status display
	DIAGN	Diagnostics display

6.2.2.1 Block diagram

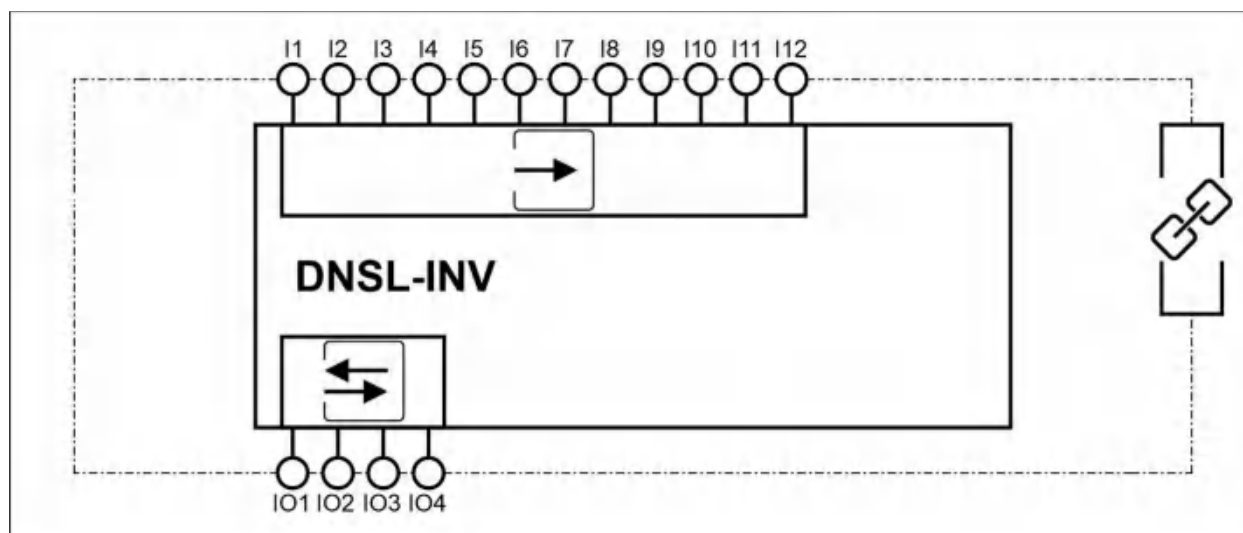

Inputs



Configurable inputs/outputs



Expansion modules interface

6.2.3 DNSL-RMV pin assignment

	I1 to I8	digital inputs
	13/14, 23/24, 33/34, 43/44	Relay outputs
	LED I1 to I8	Inputs status display
	LED K1 to K2	Relay outputs status display
	DIAGN	Diagnostics display

6.2.3.1 Block diagram

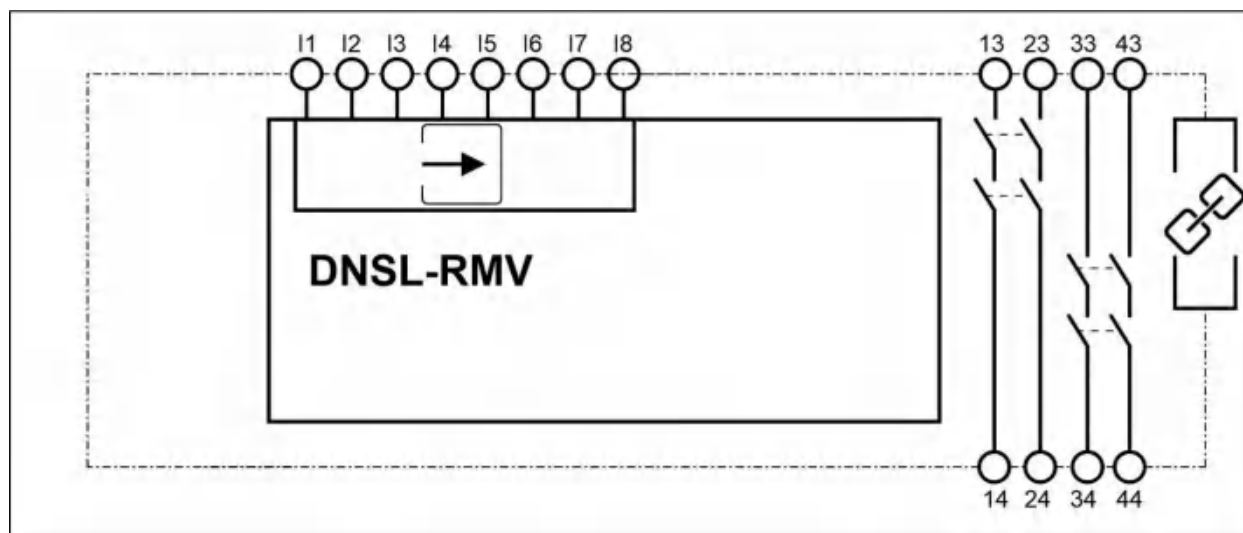

Inputs



Expansion modules interface

6.3 Speed monitoring modules

These function modules record and evaluate movements and guarantee safe switching off in the event of overspeed or movement from a standstill. These modules identify the direction of rotation and monitor the braking ramp.

Depending on the device type, a range of measurement systems can be used.

The safe inputs and outputs enable safety functions to be implemented.

The following speed monitoring modules are available:

	DNSL-DSV	DNSL-DRV	DNSL-BIV
Safe digital inputs	8	8	8
Analog inputs	-/-	-/-	-/-
Safe semiconductor outputs	5	5	7
Semiconductor outputs	2	2	-/-
Configurable inputs/outputs	-/-	-/-	-/-
Relay outputs	-/-	-/-	-/-
Measurement system encoder inputs	2 sin/cos, TTL, HTL, HTL only track A/B	2 resolvers	2 BiSS
	DNSL-SIV		
Safe digital inputs	8		
Analog inputs	-/-		
Safe semiconductor outputs	4		
Semiconductor outputs	-/-		
Configurable inputs/outputs	-/-		
Relay outputs	-/-		
Measurement system encoder inputs	2 SSI		

Outputs O1 to O4 can be configured as clocked outputs. All semiconductor outputs can be configured as dynamized outputs.



6.3.1 DNSL-DSV and DRV, BIV pin assignment

	I1 to I8	digital inputs
	O1 to O7	Semiconductor outputs
	P	Operating voltage +24 V DC
	RJ45 socket 1 to 2	Encoder interface
	LED P	Status of the supply voltage of the semiconductor outputs
	LED I1 to I8	Inputs status display
	LED O1 to O7	Outputs status display
	LED	standstill monitoring status display
	LED	Speed monitoring status display

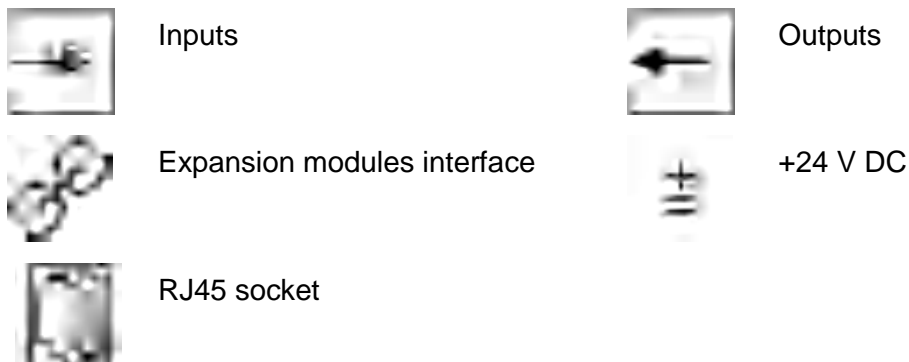
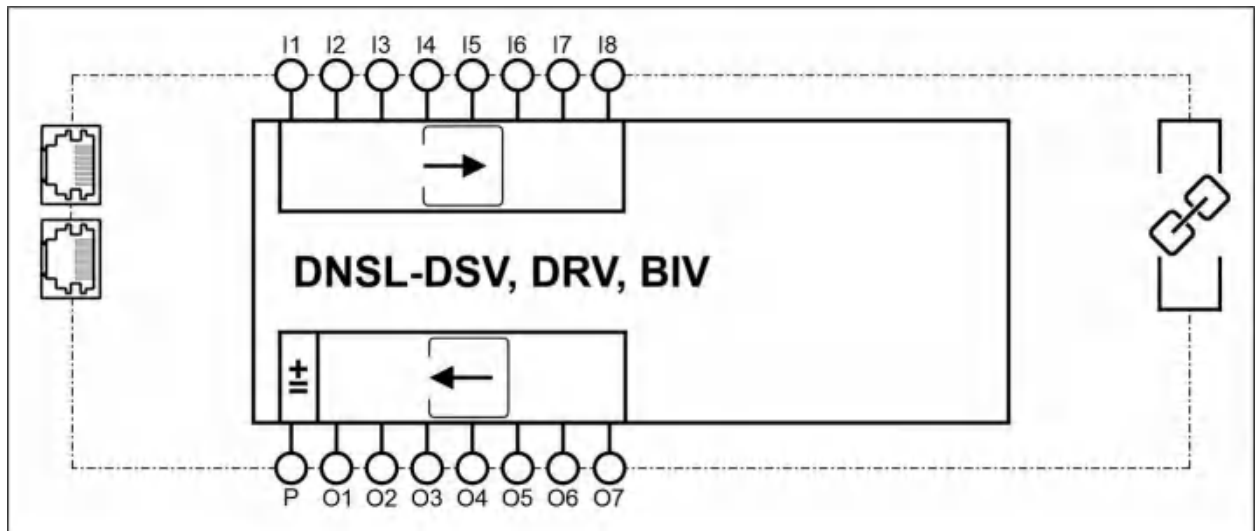
6.3.1.1 Block diagram

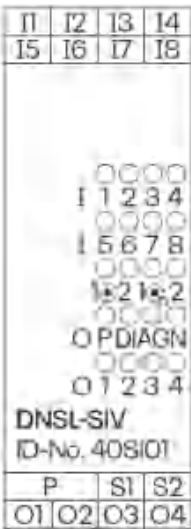

6.3.2 DNSL-SIV pin assignment

 <p> I1 I2 I3 I4 I5 I6 I7 I8 O1 O2 O3 O4 S1 S2 P LED I1 I2 I3 I4 LED O1 O2 O3 O4 LED P LED I LED n </p> <p>DNSL-SIV ID-No. 408101</p>	I1 to I8	digital inputs
	O1 to O4	Semiconductor outputs
	S1, S2	RJ45 socket shield connection S1 for enc RJ1 S2 for enc RJ2
	P	Operating voltage +24 V DC
	RJ45 socket 1 to 2	Encoder interface
	LED P	Status of the supply voltage of the semiconductor outputs
	LED I1 to I8	Inputs status display
	LED O1 to O4	Outputs status display
	LED 	standstill monitoring status display
	LED 	Speed monitoring status display



Hinweis

Terminal P is not intended for operational switching and must be connected directly to +24V.



CAUTION

The SSI encoders can be supplied with 24V voltage via the RJ45 socket. Never plug or unplug the encoder cable under voltage. There is a risk of short circuits in the signal line to the 24V voltage during the plugging process.



Note

The DNSL-SIV can only be configured as an SSI master.

6.3.2.1 Block diagram

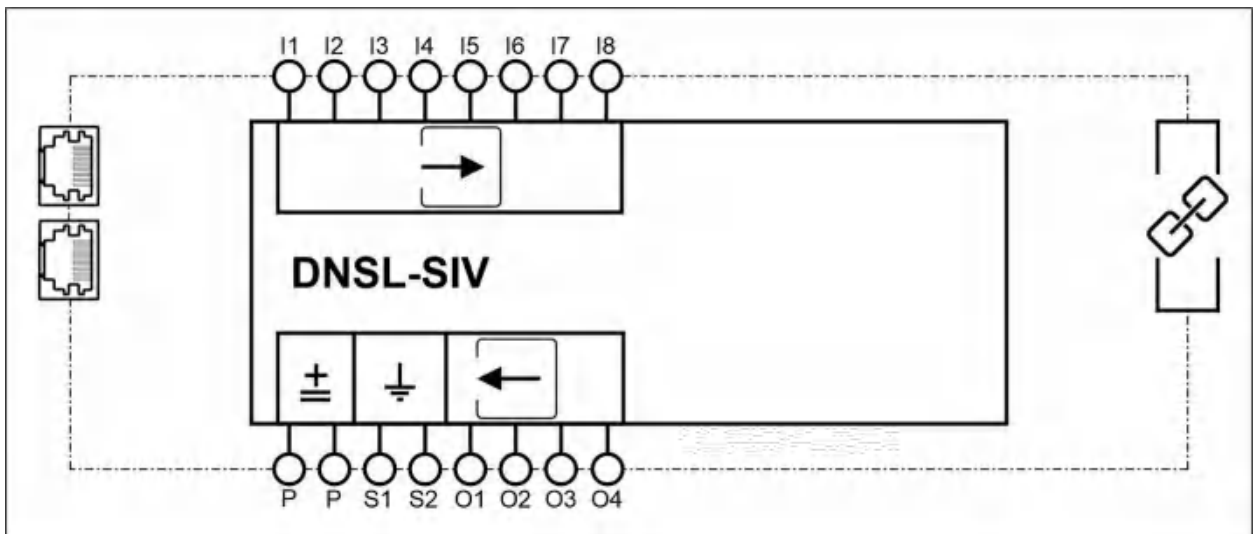

Inputs



Outputs



Expansion modules interface



+24 V DC



RJ45 socket



Shielding

6.4 Fieldbus modules

Fieldbus modules are used for exchanging diagnostic data and non-safety-relevant control commands between **SAFELINE VARIO** and the superordinate control system.

The digital inputs on the modules can be used for safety functions.

The fieldbus modules are available with different protocols.

	DNSL-COV	DNSL-DPV	DNSL-ECV	DNSL-EPV
Protocol	CAN open	Profibus DP	EtherCAT	Ethernet/IP
Safe digital inputs	8	8/10	8/10	8/10
Input data	4 bytes	4 bytes	4 bytes	4 bytes
Output data	8 bytes	8/16 bytes	8/16 bytes	8/16 bytes
	DNSL-MOV	DNSL-PLV	DNSL-PNV	
Protocol	ModBUs	PowerLink	ProfiNet	
Safe digital inputs	8/10	8	8	
Input data	4 bytes	4 bytes	4 bytes	
Output data	8/16 bytes	8 bytes	8 bytes	

6.4.1 DNSL-EPV/DPV pin assignment

	I1 to I10	digital inputs
	LED I1 to I10	Inputs status display
	LED V	Indicator: Power on
	LED S, M	Indicator: Master/slave ok

6.4.1.1 DNSL-COV/DPV block diagram, 8-pin

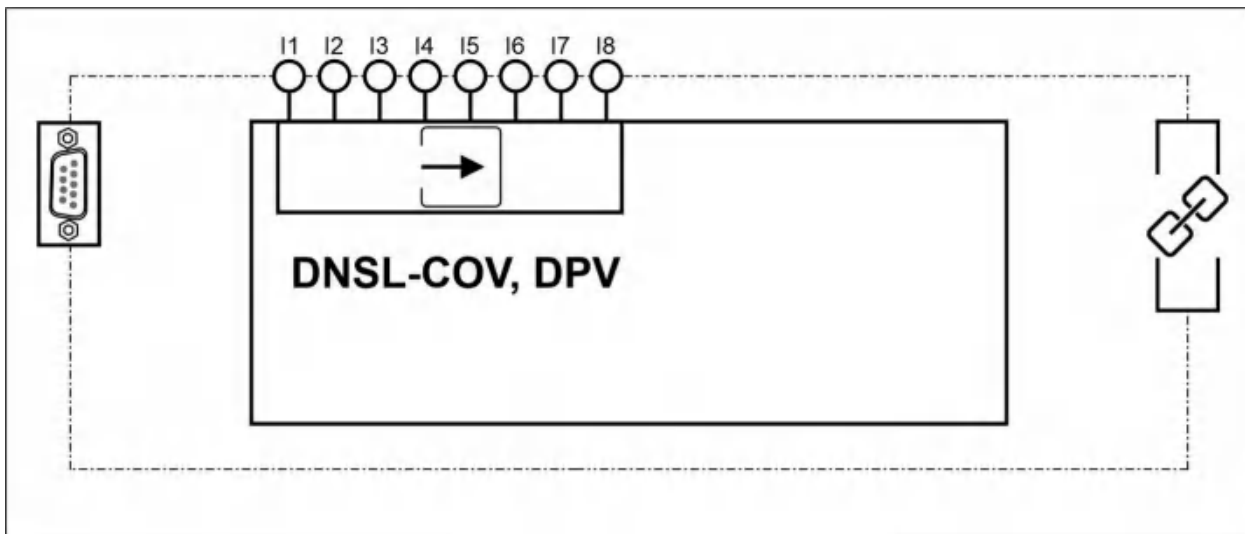

Inputs



Expansion modules interface



CANopen bus connection (COV)
Profibus DP bus connection (DPV)

6.4.1.2 DNSL-COV/DPV block diagram, 10-pin

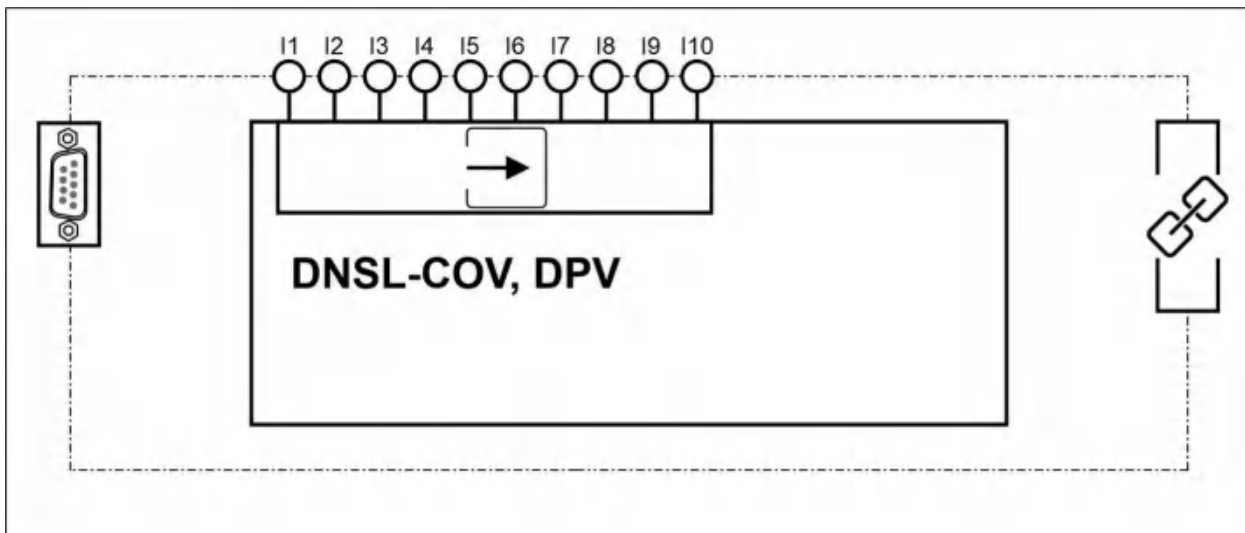

Inputs



Expansion modules interface

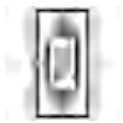

CANopen bus connection (COV)
Profibus DP bus connection (DPV)

6.4.1.3 DNSL-ECV/EPV/MOV/PLV/PNV block diagram, 8-pin

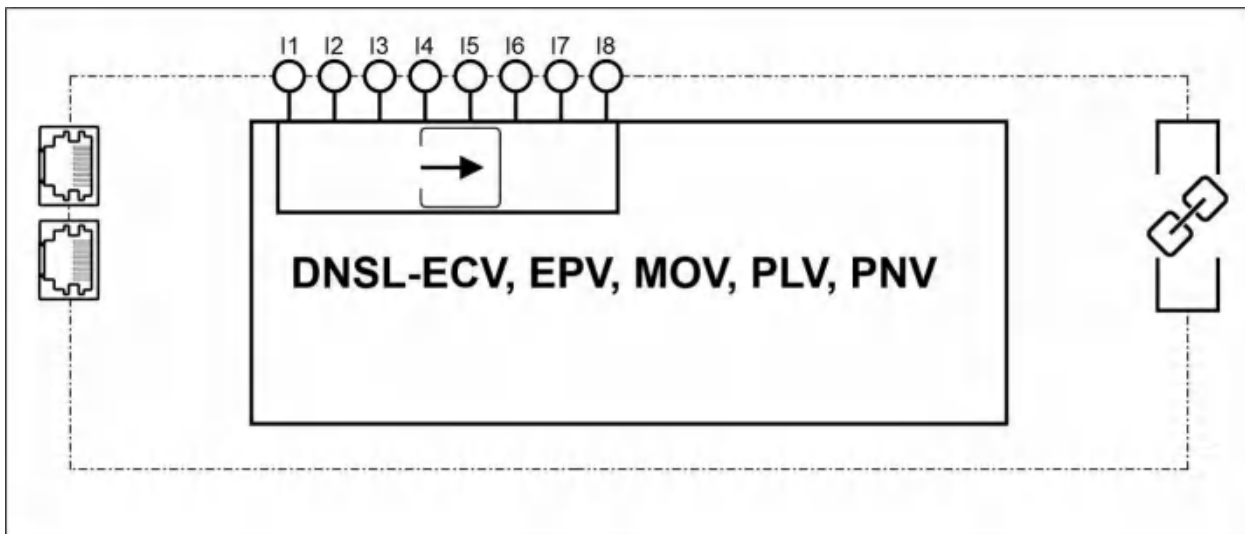

Inputs



Expansion modules interface



RJ45 socket

6.4.1.4 DNSL-ECV/EPV/MOV/PLV/PNV block diagram, 10-pin

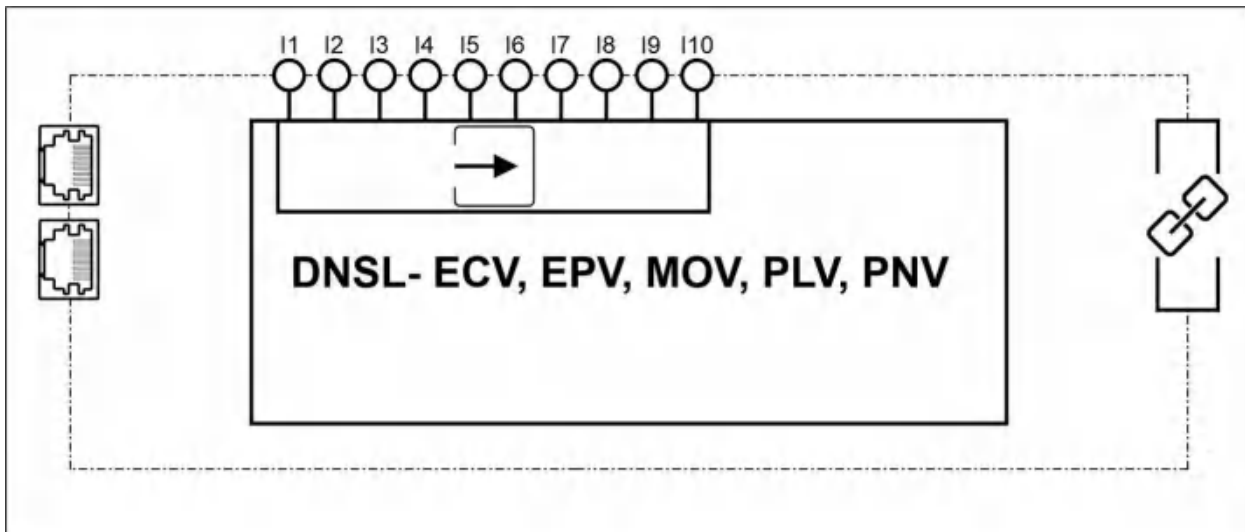

Inputs



Expansion modules interface



RJ45 socket

6.5 DNSL-CMV cascade module

The cascade module enables a safety system to be constructed decentrally. This makes it possible to house function modules in a range of control cabinets. The number of function modules must not exceed the maximum of 15.

A cascade consists of a base unit with a central module and up to five peripheral units. Each unit requires a cascade module. The units are connected to one another via patch cables. We recommend patch cables with connectors made by Hirose with the designation TM11AP-88P(61). The length of all patch cable must not exceed 100 m.

The cascading can be serial or star shaped.

The addressing (1–14) is implemented using binary coding via the cascade module input terminals.

6.5.1 Structure of a cascade

Base unit with

- Central module
- One or more function modules
- 1 cascade module in the last slot

Peripheral units with

- 1 cascade module in the first slot
- One or more function modules

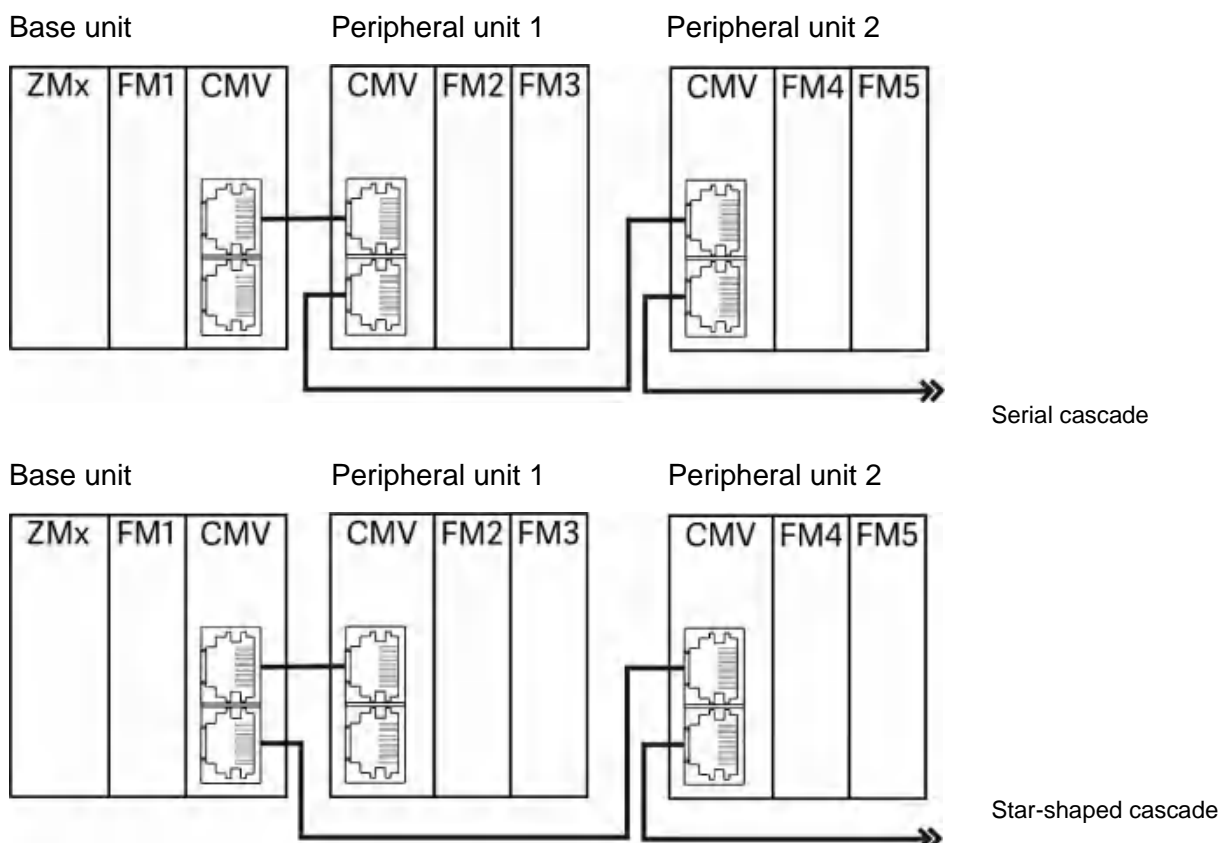

6.5.2 DNSL-CMV pin assignment

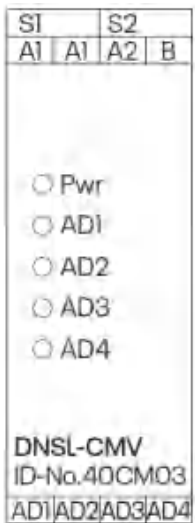
	A1	Operating voltage Peripheral unit +24 V DC
	A2	Operating voltage Peripheral unit +0 V DC
	B	Operating voltage Peripheral unit +24 V DC
	S1, S2	RJ45 patch cable shield connection S1 for RJ1, upper socket S2 for RJ2, lower socket
	AD1 to AD4	Addressing inputs
	PWR LED	Operational readiness display
	LED AD1 to AD4	Addressing inputs status display



Note

The operating voltage at terminals A1/A2 and B must be connected at the peripheral unit.

These terminals must remain free on the base unit.



Note

In the event of EMC interference, the connections S1 and S2, which are connected to the shielding of the patch cable, can optionally be grounded. However, the patch cables may only be grounded at one end so that no equalizing currents can flow through the shielding.

6.5.2.1 Block diagram

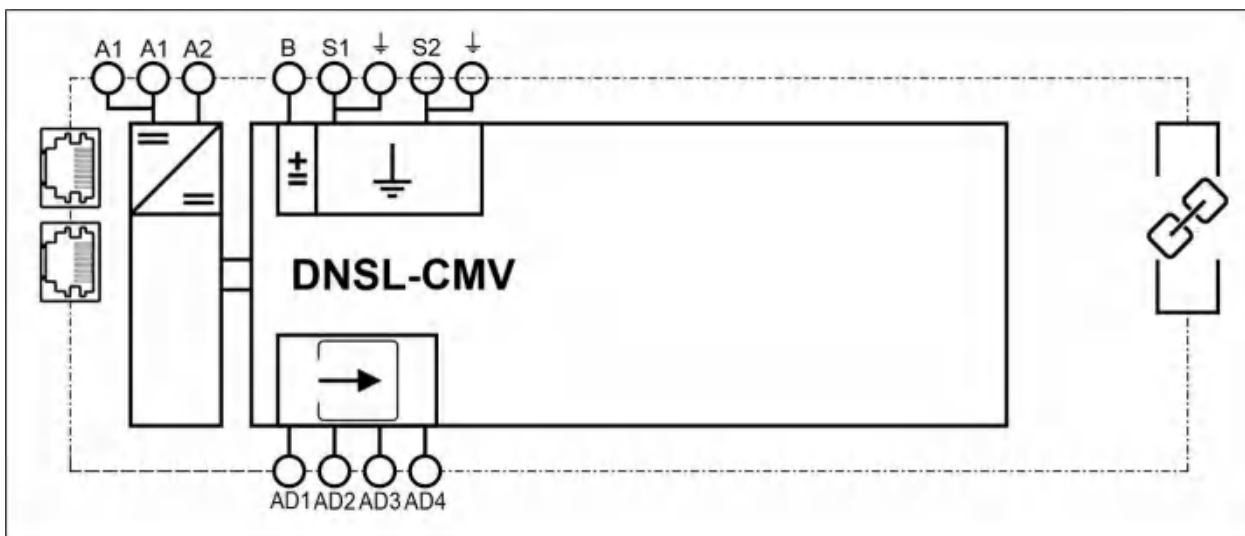

Inputs



+24 V DC



Expansion modules interface



Shield connection



RJ45 socket

6.5.3 Cascade addressing

The base unit does not have to be addressed.

The peripheral units addressing is performed on the cascade module for the corresponding peripheral unit.

The binary coded switching for the address inputs indicates the address for the first function module in the peripheral unit.

Example:

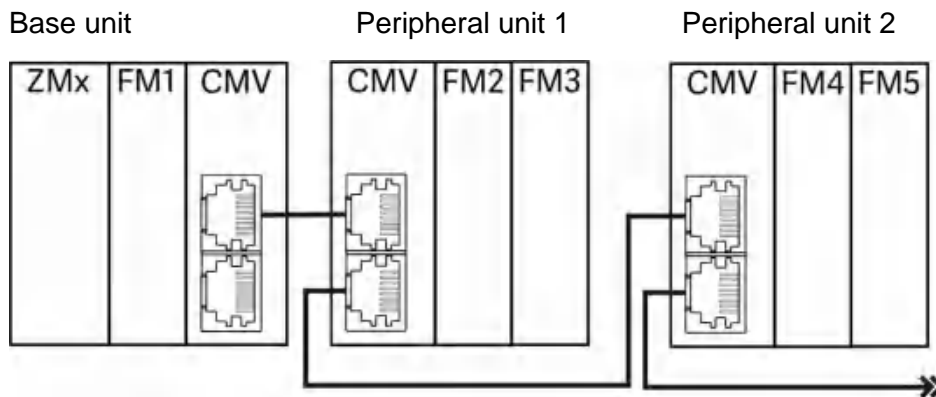

	Peripheral unit 1	Address	Peripheral unit 2	Address
Wiring	AD1 OFF AD2 ON AD3 OFF AD4 OFF	2	AD1 OFF AD2 OFF AD3 ON AD4 OFF	4

6.6 DNSL-NIV/NRV network module

The DNSL-NIV and -NRV network module is used for data exchange between up to eight base units. Each base unit requires a DNSL-NIV module, which is connected to the DNSL-NRV module.

The maximum cable length between NIV and NRV is 150 m.

For data exchange, 32 virtual inputs and 32 virtual outputs are available.

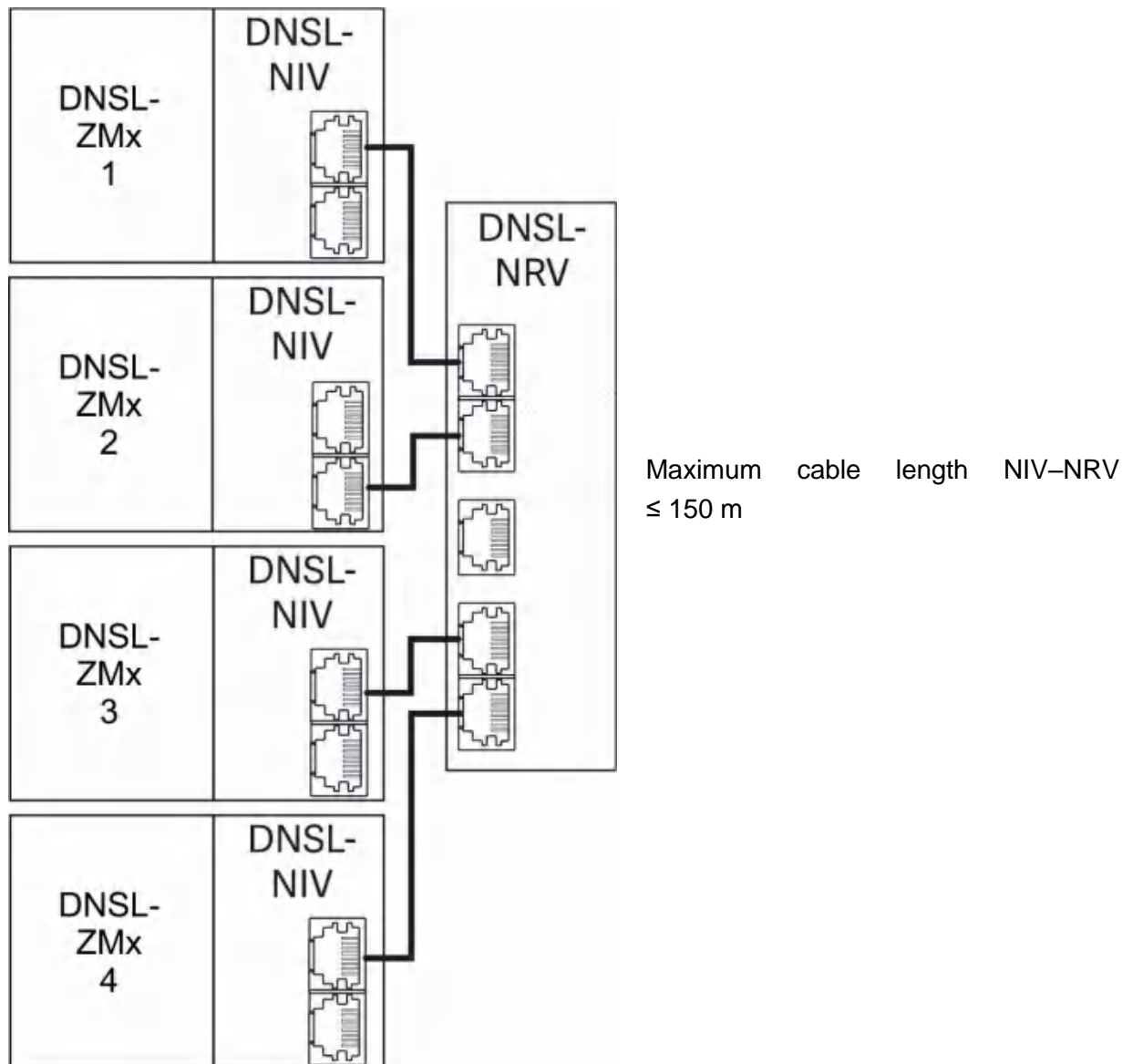

6.6.1 DNSL-NIV pin assignment

<p>DNSL-NIV ID-No. 40NID2</p>	I1 to I8	digital inputs
	O1 to O4	Semiconductor outputs
	P	Operating voltage +24 V DC
	S1, S2	RJ45 socket shield connection S1 for RJ1, upper socket S2 for RJ2, lower socket
	RJ45 socket 1 to 2	Data interface
	LED I1 to I8	Inputs status display
	LED O1 to O4	Outputs status display
	LED NW1 to NW8	Network connection display

6.6.1.1 Block diagram

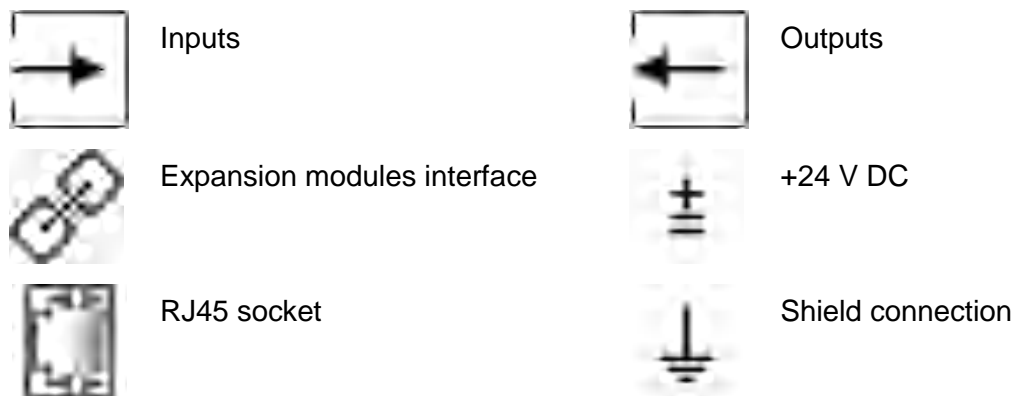
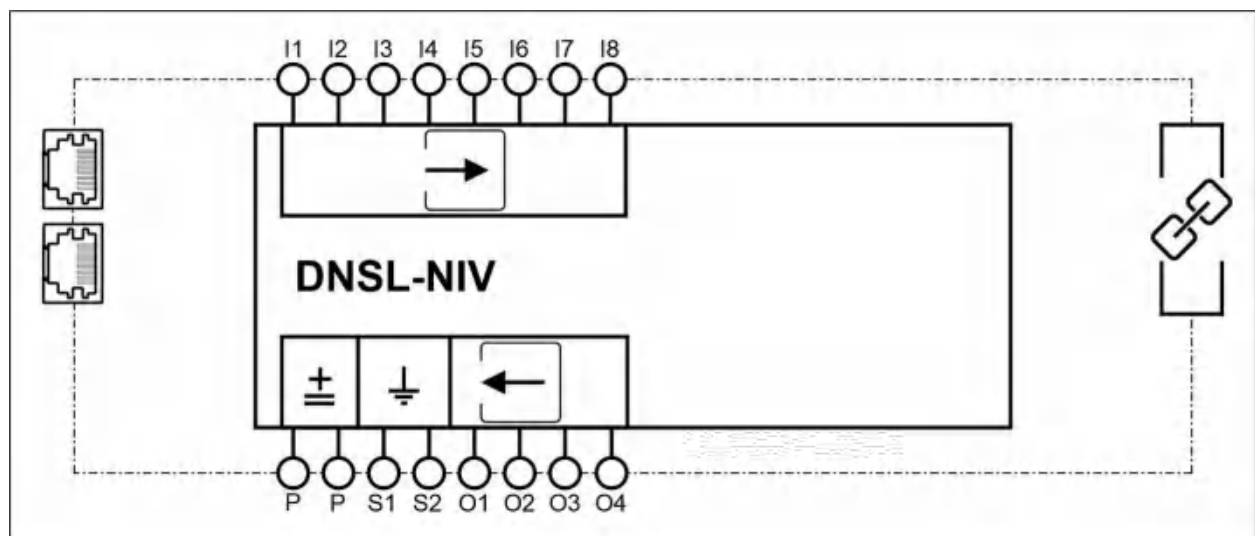

6.6.2 DNSL-NRV pin assignment

<p> ○ Pwr ○ NW1 ○ NW2 ○ NW3 ○ NW4 </p> <p> DNSL-NRV ID-No. 40NR01 MH ML SH SL </p>	A1	Operating voltage +24 V DC
	A2	Operating voltage +0 V DC
	MH, ML, SH, SL	Test terminals (for internal use by DI-NA Elektronik GmbH only)
	RJ45 socket 1 to 4, lateral	Data interfaces to DNSL-NIV 1 to 4
	RJ45 socket, front	Interface to additional DNSL-NRV
	PWR LED	Operational readiness display
	LED NW1 to NW4	Network connection display

6.6.2.1 Block diagram

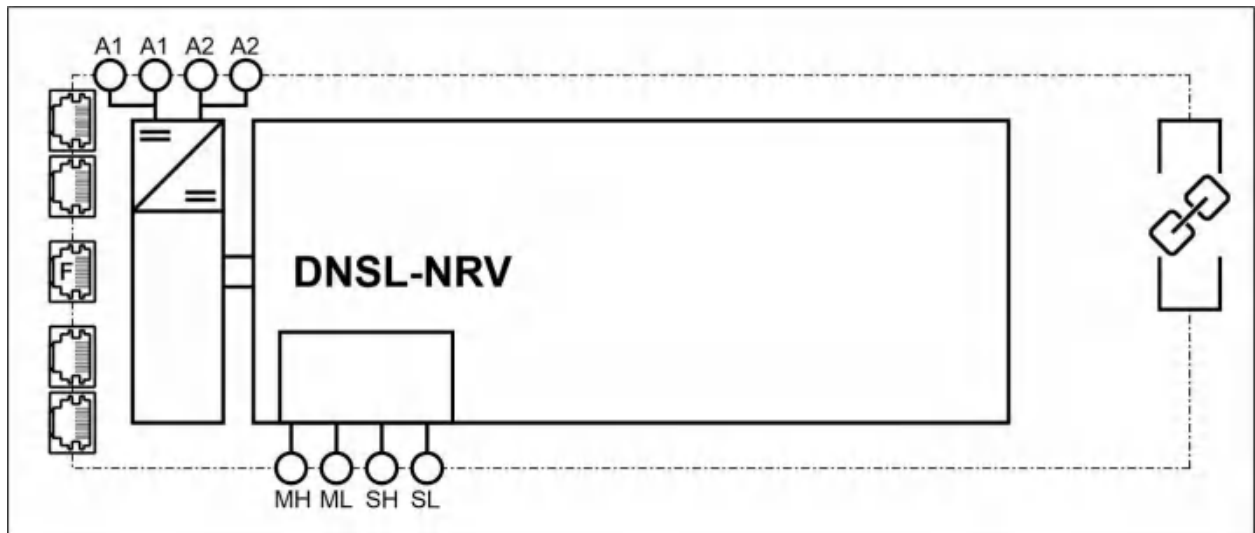

- Expansion modules interface
- RJ45 socket
- RJ45 socket, front

7 Safety functions

The inputs for the central module and function modules are intended for connecting a range of safety equipment and enable a variety of safety function.

Application examples:

- Emergency stop button
- Enabling switch
- Light grid/curtains
- Two-handed operating elements (two-handed controls/switches)

7.1 Safety circuits

The safety circuits are configured in **SL VARIO-Designer**. A range of configuration options are available and can be found in the **SL VARIO-Designer** handbook. This handbook also contains all additional function descriptions for the modules.

The safety circuits activation can be static, antivalent or clocked.

The safety circuits can be acknowledged either automatically (without additional input) or using a selected input signal (terminal, fieldbus input, virtual output). The input signal can be a static 24 V or a falling edge.

Activation of a safety circuit (SK) and acknowledgment using a falling signal edge

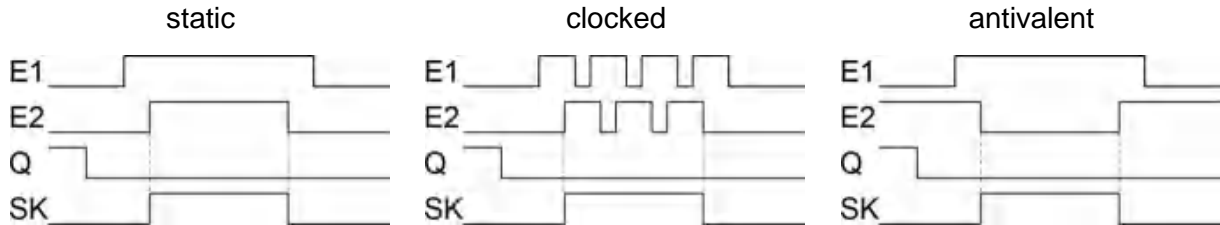

Example: Emergency stop with static activation E1, E2 and acknowledgment (Q) using a falling signal edge

Circuit diagram	Signal

Activation of a safety circuit without acknowledgment

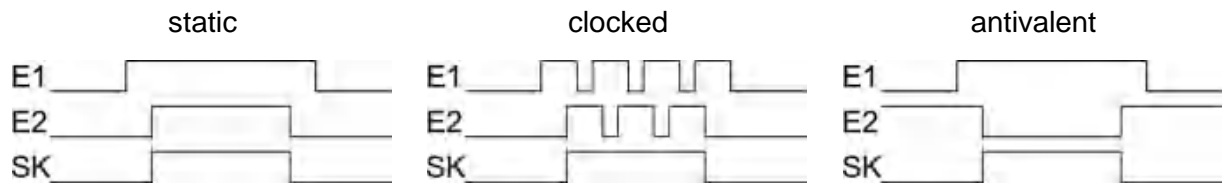

Example: Protective cover with static activation E1, E2 without acknowledgment

Circuit diagram	Signal



Note

Please note that the inputs (E1, E2, Q) for the safety devices cannot be freely selected.

7.1.1 Inputs for safety circuits without acknowledgment

SK1		SK2		SK3		SK4		...
E1	E2	E1	E2	E1	E2	E1	E2	
I1	I2	I3	I4	I5	I6	I7	I8	

7.1.2 Inputs for safety circuits with acknowledgment

SK1			SK2			SK3			...
E1	E2	Q	E1	E2	Q	E1	E2	Q	
I1	I2	I3	I4	I5	I6	I7	I8	I9	

7.1.3 Inputs for safety circuits with external acknowledgment input

SK1			SK2			SK3			...
E1	E2	Q	E1	E2	Q	E1	E2	Q	
I1	I2	ext.	I3	I4	ext.	I5	I6	ext.	

7.2 Two-handed monitoring

Safe monitoring of two-handed keys meets the requirements of ISO 13851: Type III C.

Output ZH switches on if both operating elements are activated within 500 ms. It switches off when one or both keys are released.

Times for two-handed function:

- Simultaneity t in two-handed circuit 500 ms
- Processing time < 50 ms

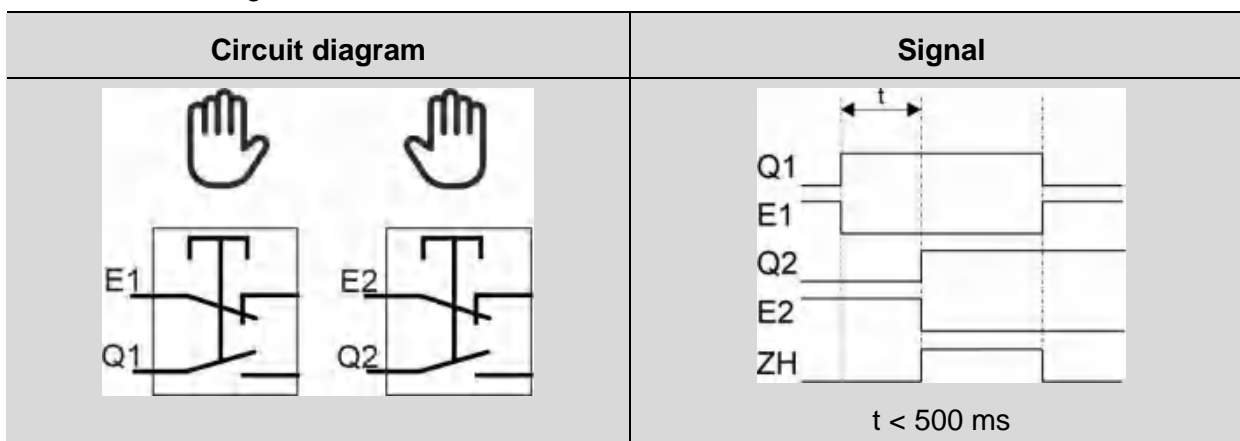

Note

Please note that the inputs for the two-hand button cannot be freely selected.

7.2.1 Inputs for two-hand monitoring

ZH1				...
E1	Q1	E2	Q2	
I1	I2	I3	I4	

7.3 Inputs for safety mats, switching strips and bumpers on the central module

Up to eight short-circuit-forming safety mats, switching strips or bumpers can be connected at inputs I1 to I8 on the central modules.

Connection scheme:

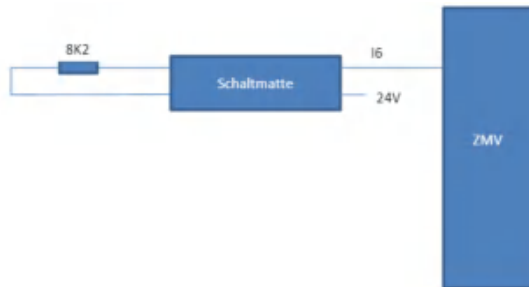

Important information for the use of switching mats, switching strips and bumpers

- ▶ The safety equipment must only be installed and commissioned by a skilled electrician or a correspondingly trained person, who is familiar with these operating instructions and the corresponding country-specific applicable specifications regarding occupational health and safety and accident prevention.
- ▶ Before commissioning for the first time, and at regular intervals that depend on the signaling device, all required tests (function, status, measurement and arrangement) must be performed on the safety equipment by the operator.
- ▶ If contact outputs are used, the safety function must be requested at least once per month for Performance Level e (PLe) and once per year for Performance Level d (PLd).
- ▶ The maximum length of the connection wire depends on the surroundings and wire cross section, and must be observed. Recommended: $L_{max} = 20 \text{ m}$.
- ▶ The minimum distance between the signaling device and protective equipment must be determined in accordance with DIN EN ISO 13855. When doing so, the reaction time of the entire system must be considered.
- ▶ The specifications in the operating instructions for the signaling device in use must be observed and followed.
- ▶ The functional parameters for the signaling device and evaluation unit must always be complied with.
- ▶ The contact load for the output switching equipment must be chosen so that the application-specific minimum switching cycles can be reached. This equipment must be replaced at the end of its service life. After successful replacement, the efficacy of the entire implemented safety system must be validated.
- ▶ Replaced parts must be disposed of properly.

8 Standstill and speed monitoring

On the central modules, inputs I9 to I16 are available to record speed. The rotation can be recorded by a proximity switch or incremental HTL measurement system.



On the speed monitoring modules, the measurement system is only connected to the RJ45 socket connectors.

8.1.1 Features of rotation monitoring

- Safe monitoring of multiple independent axles
- Connection option per axle
 - 1 incremental encoder
or
 - 2 proximity switches (module-dependent)
- Measured values
 - Standstill
 - Speed
 - Direction of rotation
 - Brake
 - Braking ramp (module-dependent)
- 4 operating modes
- Encoder types can be selected in the configurator
- A range of cable adapters with different plug connectors are available for connecting the speed monitoring to the measurement system. For more information, please contact **DI-NA Support**.

8.1.1.1 Requirements for the incremental encoder

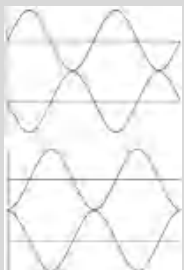
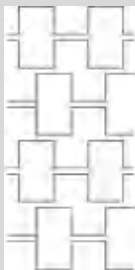
It is possible to assess the following incremental encoders:

Measurement system		Measurement system	
<ul style="list-style-type: none"> sin/cos 1 Vss 		<ul style="list-style-type: none"> TTL Low : < 0,5V High : > 4V HTL Low : < 3V High : > 20 V 	
<ul style="list-style-type: none"> Resolver 1 V–10 V 		<ul style="list-style-type: none"> SSI BiSS 	

8.1.1.2 Requirements for the proximity switch

The proximity switch

- must be PNP-switching
- must have a supply voltage of 24 V DC
- must be connected so that at least one is always dampened (high signal leads)
- must be connected so that the recorded signals overlap

Proximity switch 1

Proximity switch 2

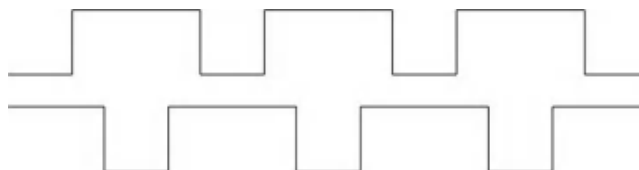

8.1.1.3 Overview of measurement systems

Module	Measurement inputs	Measurement system	Number	Functions	PL	Frequency range
DNSL-ZMV	I9 to I12	Proximity switch	4x single-channel	Standstill Speed	PLc	5 Hz– 500 Hz
	I9, I10 I11, I12	Proximity switch	2x safe	Standstill Speed	PLe	5 Hz– 500 Hz
	I9 to I16	HTL	2	Standstill Speed Direction Brake	PLd	50 Hz– 50 kHz
DNSL-ZMVD	RJ45 socket	sin/cos TTL HTL	4/8	Standstill Speed Direction Brake	PLd	50 Hz– 300 kHz
DNSL-DSV	RJ45 socket	sin/cos TTL HTL TTL/HTL (only track A, B) RS422 (low < 1.7 V) Proximity switch	2	Standstill Speed Direction Brake Braking ramp	PLe	50 Hz– 500 kHz
DNSL-DRV	RJ45 socket	Resolver	2	Standstill Speed Direction	PLe	1 Hz– 1200 Hz
DNSL-SIV	RJ45 socket	SSI	2	Standstill Speed Direction	PLd	10 Hz– 500 kHz
DNSL-BIV	RJ45 socket	BiSS	2	Standstill Speed Direction Brake	PLd	0,18 U/min – 30000 U/min

8.1.1.4 Connection options at the measurement inputs on the DNSL-ZMV

Speed recording (DSx) at inputs I9 to I16 on the DNSL-ZMV can be single-channel (1 sensor), double-channel (2 sensors) or via HTL encoders.

Variant 1:

	DS1	DS2	DS3	DS4	DS6			
Measurement system	Sensor 1	Sensor 2	Sensor 3	Sensor 4	HTL			
					+A	+B	-A	-B
Inputs	I9	I10	I11	I12	I13	I14	I15	I16

Variant 2:

	DS1		DS3	DS4	DS6			
Measurement system	Sensor 1	Sensor 2	Sensor 3	Sensor 4	HTL			
					+A	+B	-A	-B
Inputs	I9	I10	I11	I12	I13	I14	I15	I16

Variant 3:

	DS1		DS3		DS6			
Measurement system	Sensor 1	Sensor 2	Sensor 3	Sensor 4	HTL			
					+A	+B	-A	-B
Inputs	I9	I10	I11	I12	I13	I14	I15	I16

Variant 4:

	DS5				DS6			
Measurement system	HTL				HTL			
	+A	+B	-A	-B	+A	+B	-A	-B
Inputs	I9	I10	I11	I12	I13	I14	I15	I16

8.1.1.5 DNCO functions

The DNCO function of the DNSL-DSV, DNSL-DRV, DNSL-BIV and DNSL-ZMV modules enables speed monitoring of

- up to 16 different speeds or rotational speeds per encoder input and per operating mode or
- up to 64 different speeds or rotational speeds per encoder input and in automatic mode.

The speeds/rotational speeds are stored in two frequency tables (DNCO1 and DNCO2). The assignment of which encoder input accesses which table is made in the parameter screen of the corresponding speed monitoring module.

The frequency is then selected using the bit-coded circuitry of defined inputs on the central module or the function modules. 4 or 6 inputs are provided for this purpose. Using 4 inputs, the frequencies for all operating modes can be selected. If more than 16 frequencies are required, 6 inputs can be used for this purpose. In this case, however, the DNCO function can only be used in automatic operating mode.

Alternatively, the frequency can be selected in all operating modes using selected inputs. To do so, the "DNCO multiplexer" logic module must be located in the application.

The DNCO1 control module is available for actuating the inputs.

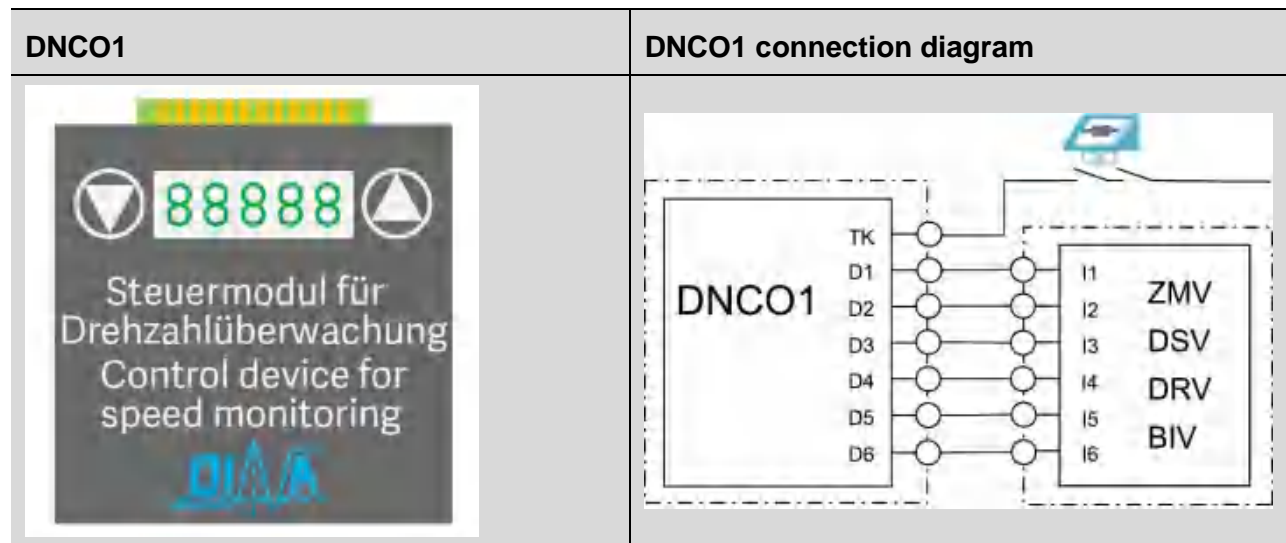

9 Diagnostics and switching status displays

The modules are equipped with an LED display for

- supply voltage
- status of inputs and outputs
- diagnostics
- faults

Additionally, the parameterization software offers comprehensive online diagnostics options. A description of these can be found in the **SL VARIO-Diagnostics** operating instructions.

9.1 LED indicators

The corresponding system is ready for operation when the PWR LEDs are lit on the central module.

Key



LED on



LED off



LED flashing

Central module		State	
PWR			
			Data transmission
			Error
			OK not valid
			Valid
			Synchronizing
			Error
			OK

Additional statuses:

- LED on => inputs and outputs are wired (applies to all modules)

If the inputs on the central module are used as analog inputs, the following statements apply:

- LED on if voltage/current are within the parameterized range
- LED off if voltage/current are outside the parameterized range
- LED flashes if the measured value is 0 V, i.e. a wire has broken

If the inputs on the central module are used as frequency inputs, these flash according to the applied frequency.

Clocked output pairs are displayed as flashing alternately.

LEDs indicating the standstill and speed monitoring

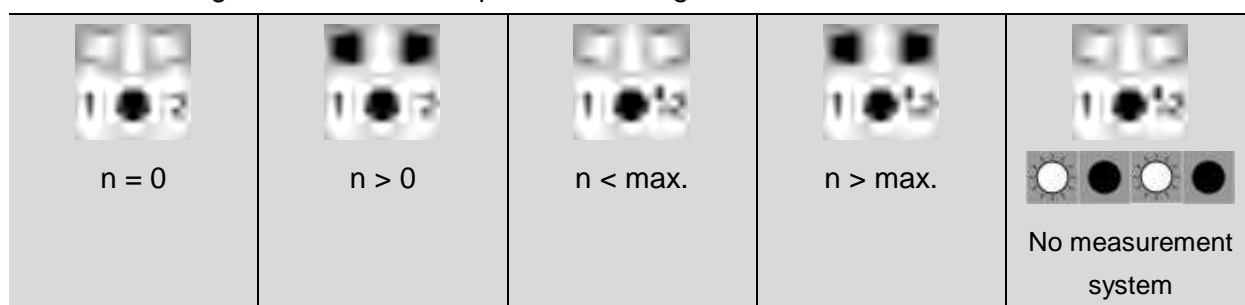

Exception: DNSL-ZMVD module with DS1/DS2 expansion.

DNSL-ZMVD/DS1/DS2 LEDs

DS1 LEDs				DS2 LEDs			
1	2	3	4	5	6	7	8

Switching status display for the DNSL-ZMVD/DS1/DS2 standstill and speed monitoring





















LED 1–8: Monitoring 1–8	State
	$n = 0$
	$n > 0 < \text{max.}$
	$n > \text{max.}$
	$n > \text{max.}$
	No measurement system

9.2 Diagnostics LEDs

Function modules

- DNSL-INV
- DNSL-IOV
- DNSL-RMV

have 4 diagnostics LEDs.

Module	 DIAGN				State
DNSL-INV					CAN communication OK
					Module function OK
					No CAN communication
DNSL-IOV					Always lit
DNSL-RMV					Always lit

10 Example of application

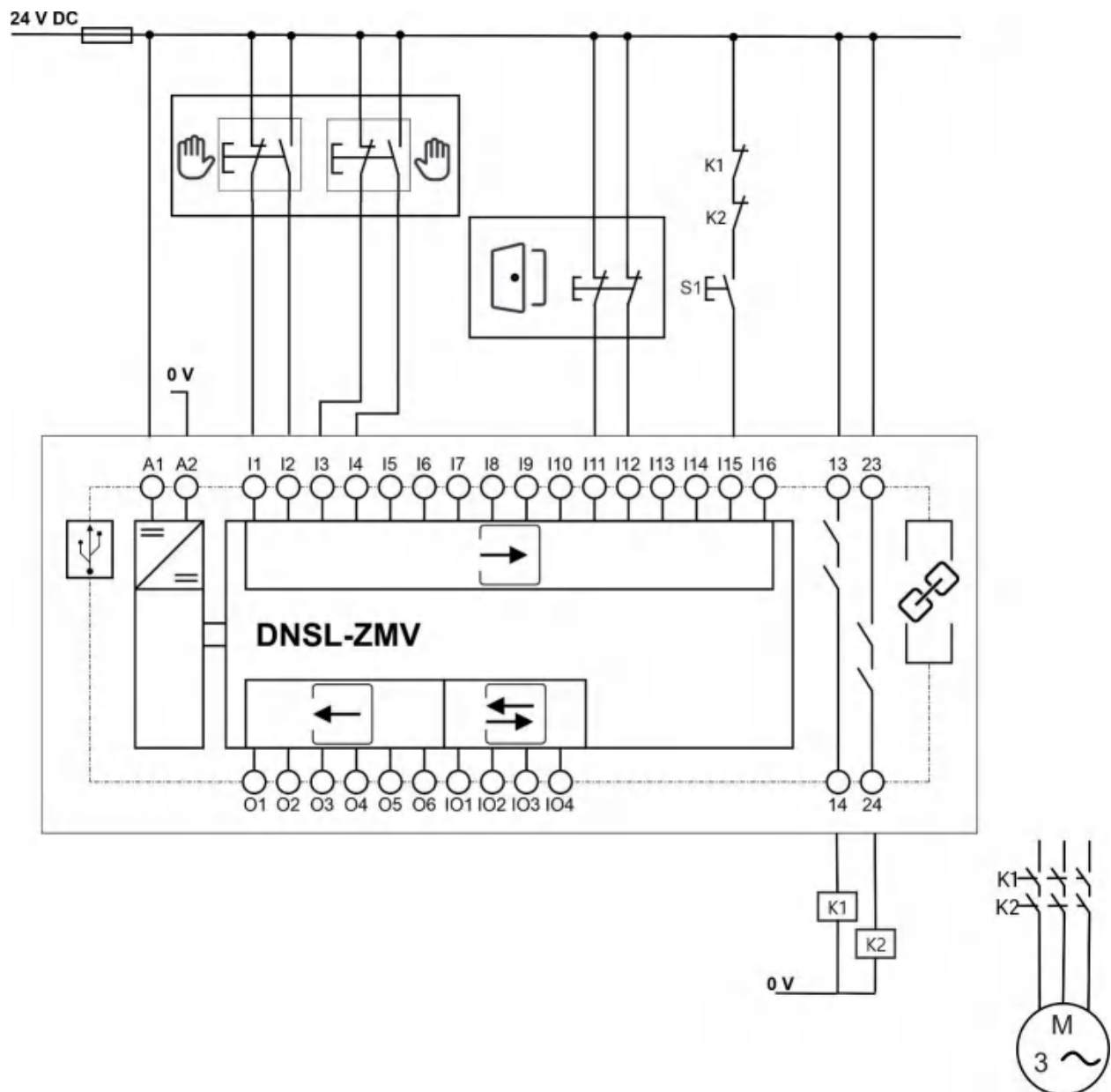

Legend:

 Two-hand button

 Protective door

S1 Unlocking protective door

11 Technical data

11.1 Supply

Module	Operating voltage (A1+A2)	Input current (A1)	Input current (P)	Power consumption
DNSL-ZMV	24 V DC (-15/+10%)	≤ 4 A	-/-	2.9 W
DNSL-ZMVD	24 V DC (-15/+10%)	≤ 4 A	-/-	3.0 W
DNSL-ZMVK	24 V DC (-15/+10%)	≤ 4 A	-/-	7.7 W
DNSL-DSV	-/-	-/-	≤ 4 A	2.5 W
DNSL-DRV	-/-	-/-	≤ 4 A	2.5 W
DNSL-SIV	-/-	-/-	≤ 4 A	2.2 W
DNSL-BIV	-/-	-/-	≤ 4 A	2.2 W
DNSL-INV	-/-	-/-	-/-	1.7 W
DNSL-IOV	-/-	-/-	≤ 4 A	2.2 W
DNSL-CMV	-/-	-/-	-/-	0.5 W
DNSL-NIV	-/-	-/-	≤ 4 A	2.2 W
DNSL-NRV	-/-	-/-	-/-	2.2 W
DNSL-RMV	-/-	-/-	-/-	4.8 W
Fieldbus	-/-	-/-	-/-	1.0 W

11.2 Inputs



Note

Signal inputs must not become active before stable, valid voltage at A1!

Voltage at the inputs	24 V DC (-15/+10%), ≤ 10% residual ripple
Current consumption of inputs	Max. 4.0 mA
Input voltage for terminal P on -DSV, -DRV, -BIV, -SIV, -IOV, -NIV	24 V DC (-15/+10%)
Input frequency for I9 to I12 on the central module on DNSL-ZMV, -ZMVK	≤ 500 Hz via 2 sensors, e.g. proximity switch
Input frequency for I9 to I16 on the central module on DNSL-ZMV, -ZMVK	≤ 50 KHz for HTL signals via incremental measurement system
Input frequency for DNSL-DSV	≤ 500 KHz sin/cos 1 V _{ss} or TTL signals
Input frequency for DNSL-DRV	≤ 1200 Hz sin/cos 1 to 10 V _{ss}
Input signal for DNSL-BIV	Max. 10 MHz
Input signal for DNSL-SIV	SSI interface signals
Accuracy of analog inputs	± 3% of the end value
Input impedance of analog inputs	At 4 to 20 mA = 500 Ω, at 0 to 10 V = > 5 KΩ
Type of two-hand device according to ISO 13851:2019	III C
Simultaneity t in the two-hand circle	500 ms
Inputs for safety mats, switching stripes and bumpers	I1 to I8
Voltage	Safety mat activated: 24 V Safety mat nominal: 11,5 V Safety mat undamped: 9,5 to 14 V
Reaction time	< 25 ms
Recommended length of the connection cable	< 20m

**CAUTION**

Danger for material! Current inputs (4 to 20 mA) can be disrupted at an input voltage > 12 V.

- ▶ Ensure that the input voltage is less than 12 V.

11.3 Semiconductor outputs





Note

- The utilization categories considered as standard apply to the semiconductor outputs.
- Semiconductor outputs are switched off internally at A2 in the event of a wire break. There is no residual voltage/current.
- The voltage drop in the conductive state and $I = 1\text{ A}$ measures 23.7V.
- Semiconductor outputs are short circuit- and overload-safe.

Module	Outputs	Output type	Switching/continuous current	Total switching/continuous current	Min. switching current
DNSL-ZMV DNSL-ZMVK DNSL-ZMVD	IO1 to IO4		0,1 A	0,4 A	1 mA
DNSL-ZMV DNSL-ZMVK DNSL-ZMVD	O1 to O6		1 A	3 A	1 mA
DNSL-DSV DNSL-DRV	O1, O2 O3 to O7		1 A	4 A	1 mA
DNSL-DSV2	O1 to O7		1 A	4 A	1 mA
DNSL-BIV	O1 to O7		1 A	4 A	1 mA
DNSL-INV	IO1 to IO4		0,1 A	0,4 A	1 mA
DNSL-IOV	O1 to O7		1 A	4 A	1 mA
DNSL-NIV DNSL-SIV	O1 to O4		1 A	4 A	1 mA

11.4 Contact outputs

	DNSL-ZMV DNSL-ZMVK DNSL-ZMVD	DNSL-ZMVK	DNSL-RMV
Outputs	K1, K2	K3 to K6	K1, K2
Contact material	AgNi	AgCuNi	AgNi
Output guidance			
Min. switching current	10 mA	10 mA	10 mA
Switching capacity as per DIN EN 60947-4-1 and -5-1	DC13: 24 V / 2 A AC15: 250 V / 3 A	DC1: 24 V / 6 A DC13: 24 V / 4 A / 0,1 Hz	DC13: 24 V / 2 A DC13: 24V / 4 A / 0,1 Hz AC15: 250 V / 3 A
Switching capacity according to UL 508	R300	B300/R300	B300/R300
Total switching and continuous currents	K1, K2: ≤ 6 A	K3 bis K6: ≤ 6 A	K1, K2: ≤ 6 A
Mechanical service life	> 50 x 10 ⁶	> 10 x 10 ⁶	> 40 x 10 ⁶
Contact fuse	6 A gG	6 A gG	6 A gG
Short-circuit resistance	200A/BG 800A/6A gG	1000A SCPD 6A	200A/B6 800A/6A gG
Typical response/release time	15 ms / 5 ms	10 ms / 3 ms	10 ms / 5 ms

11.5 General data

Type of protection(housing and terminals)	IP 20		
Type of protection (place of installation)	Min. IP 54		
Rated insulation voltage	DNSL-ZMV DNSL-ZMVK DNSL-ZMVD	DNSL-ZMVK	DNSL-RMV

	250 V AC	50 V AC	250 V AC
Rated surge voltage/insulation	4 KV	0,8 kV	4 KV
Degree of contamination	2		
Overtoltage category	III		
Housing material	Polyamide (PA), not reinforced		

11.6 Connection data

Terminals	Push-in terminals, pluggable
Connection cross-section	0.25 to 2.5 mm ²
Connection cross-section AWG	24...12
Wiring type	Flexible with ferrules
Stripping length	10 mm

11.7 Environmental conditions

Operating temperature	-10 °C to +55 °C
Storage temperature	-40 °C to +85 °C
Altitude of place of use	< 2000 m above sea level
Vibration resistance (in 3 planes)	sin 10 to 55 Hz, 0.35 mm (0.014 in), 10 cycles, 1 octave/min.
Output relay shock resistance (in 3 planes)	≤ 5 g, 11 ms

11.8 Dimensions

Module	Height
All	114 mm (4.488 in)
Module	Depth
All	111 mm (4.370 in)

Module	Width
DNSL-ZMV	45 mm (1.772 in)
DNSL-ZMVK	67.5 mm (2.657 in)
DNSL-ZMVD (44ZM01 – with 4 standstill and speed monitoring)	67.5 mm (2.657 in)
DNSL-ZMVD (48ZM01 – with 8 standstill and speed monitoring)	90 mm (3.543 in)
DNSL-DSV, -DRV, -SIV, -BIV	22.5 mm (0.886 in)
DNSL-INV, -IOV, -RMV	22.5 mm (0.886 in)
DNSL-CMV	22.5 mm (0.886 in)
DNSL-NIV, DNSL-NRV	22.5 mm (0.886 in)
DNSL-COV, -DPV, -ECV, -EPV, -MOV, -PLV, -PNV	22.5 mm (0.886 in)
Module	Weight
DNSL-ZMV	350 g
DNSL-ZMVD	450 g
DNSL-ZMVK	570 g
DNSL-DSV	130 g
DNSL-DRV	130 g
DNSL-SIV	130 g
DNSL-BIV	130 g
DNSL-INV	130 g
DNSL-IOV	130 g
DNSL-CMV	130 g
DNSL-NIV	130 g
DNSL-NRV	130 g

DNSL-RMV	140 g
Fieldbus	130 g

11.9 Safety-related parameters acc. to DIN EN ISO 13849-1:2016-06

Module	MTTFd [a]	Cat./PL	PFHd
DNSL-ZMV	98	4/e	2.4×10^{-8}
DNSL-ZMVK	37	4/e	7.7×10^{-8}
DNSL-ZMVD	92	4/e	2.7×10^{-8}
DNSL-ZMVD2	86	4/e	3.0×10^{-8}
DNSL-DSV	97	4/e	2.5×10^{-8}
DNSL-DSV2	100	4/e	2.47×10^{-8}
DNSL-DRV	97	4/e	2.5×10^{-8}
DNSL-SIV	100	3/d	$1,01 \times 10^{-7}$
DNSL-BIV	100	3/d	$1,01 \times 10^{-7}$
DNSL-INV	238	4/e	1.4×10^{-8}
DNSL-IOV	97	4/e	2.5×10^{-8}
DNSL-RMV	91	4/e	2.5×10^{-8}
DNSL-CMV	91	4/e	2.5×10^{-8}
DNSL-NIV	100	3/d	$1,01 \times 10^{-7}$
DNSL-DPV	305	4/e	8.0×10^{-9}
DNSL-ECV	305	4/e	8.0×10^{-9}
DNSL-COV	305	4/e	8.0×10^{-9}
DNSL-EPV	305	4/e	8.0×10^{-9}
DNSL-MOV	305	4/e	8.0×10^{-9}
DNSL-PLV	305	4/e	8.0×10^{-9}
DNSL-PNV	305	4/e	8.0×10^{-9}

11.10 Contact service life

Electrical life of the output contacts determined by DIN EN 60947-5-1 / Annex C.3

DNSL-ZMV, -ZMVK, ZMVD K1 und K2

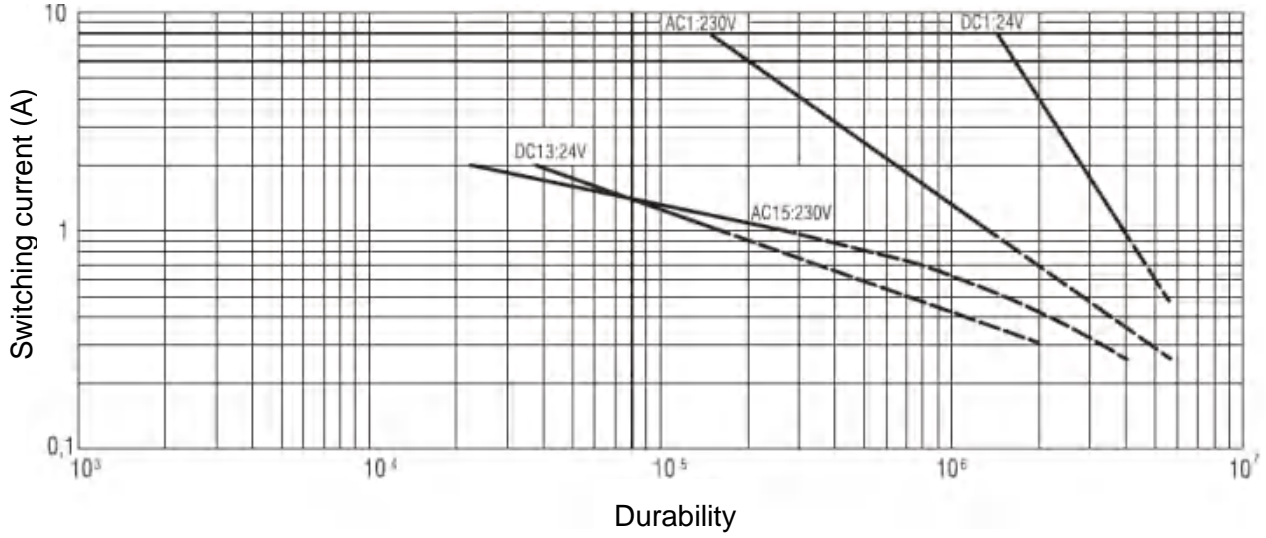

DNSL-ZMVK K3 bis K6

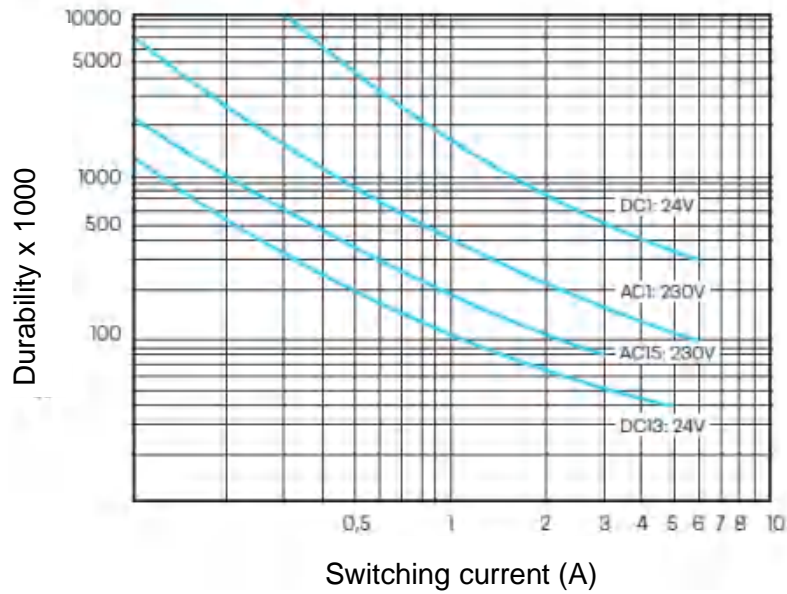

DNSL-RMV K1 und K2

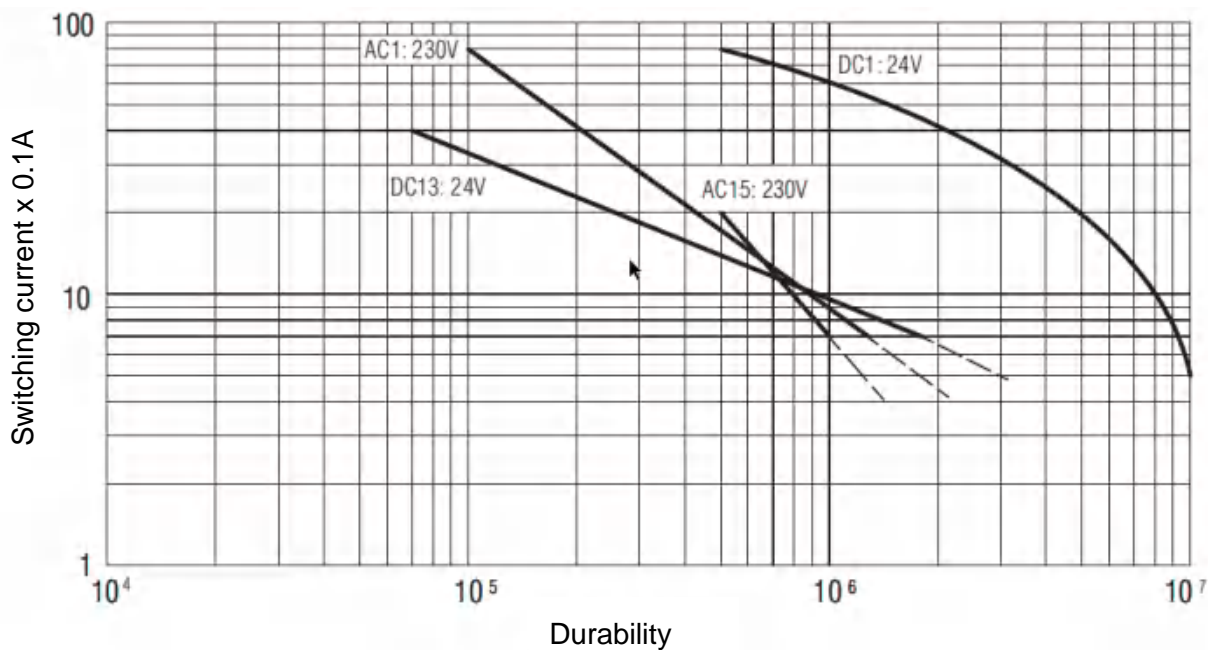

Note

The specifications regarding the contact service life of the modules in the table below are based on the following factors:

260 working days per year, 8 working hours per day

Module	Outputs	Load type	Switching current	Switching cycles per hour	Years
DNSL-ZMV DNSL-ZMVK DNSL-ZMVD	K1, K2	DC1	1,0 A	384	5
				192	10
				96	20
DNSL-ZMV DNSL-ZMVK DNSL-ZMVD	K1, K2	DC1	4,0 A	192	5
				96	10
				48	20
DNSL-ZMV DNSL-ZMVK DNSL-ZMVD	K1, K2	DC13	1,0 A	15	5
				7	10
				3,5	20

Module	Outputs	Load type	Switching current	Switching cycles per hour	Years
DNSL-ZMV DNSL-ZMVK DNSL-ZMVD	K1, K2	DC13	2,0 A	4	5
				2	10
				1	20
DNSL-ZMVK	K3 bis K6	DC1	1,0 A	144	5
				72	10
				36	20
DNSL-ZMVK	K3 bis K6	DC1	4,0 A	40	5
				20	10
				10	20
DNSL-ZMVK	K3 bis K6	DC13	1,0 A	10	5
				5	10
				2,5	20
DNSL-ZMVK	K3 bis K6	DC13	4,0 A	4	5
				2	10
				1	20
DNSL-RMV	K1, K2	DC1	1,0 A	768	5
				384	10
				192	20
DNSL-RMV	K1, K2	DC1	4,0 A	192	5
				96	10
				48	20

Module	Outputs	Load type	Switching current	Switching cycles per hour	Years
DNSL-RMV	K1, K2	DC13	1,0 A	84	5
				42	10
				21	20
DNSL-RMV	K1, K2	DC13	4,0 A	8	5
				4	10
				2	20
DNSL-ZMV DNSL-ZMVK DNSL-ZMVD	K1, K2	AC1	1,0 A	96	5
				48	10
				24	20
DNSL-ZMV DNSL-ZMVK DNSL-ZMVD	K1, K2	AC1	4,0 A	20	5
				10	10
				5	20
DNSL-ZMV DNSL-ZMVK DNSL-ZMVD	K1, K2	AC15	1,0 A	24	5
				12	10
				6	20
DNSL-ZMV DNSL-ZMVK DNSL-ZMVD	K1, K2	AC15	2,0 A	2	5
				1	10
				0,5	20
DNSL-RMV	K1, K2	AC1	1,0 A	84	5
				42	10
				21	20
DNSL-RMV	K1, K2	AC1	4,0 A	2	5

Module	Outputs	Load type	Switching current	Switching cycles per hour	Years
				1	10
				0,5	20
DNSL-RMV	K1, K2	AC15	1,0 A	84	5
				42	10
				21	20
DNSL-RMV	K1, K2	AC15	2,0 A	48	5
				24	10
				12	20

12 Installation and removal

12.1 Installing a module

12.1.1 Overview

- (A) 70–75 mm (2.756–2.953 in)
- (1) Top hat rail
- (2) Locking slider
- (3) Cable duct
- (4) Bus connector

Procedure

- ▶ Mount the bus connector (4) on the top hat rail (1).
- ▶ Hook the module onto the top hat rail and press it downward.
- ◀ The locking slider (2) engages under the top hat rail.

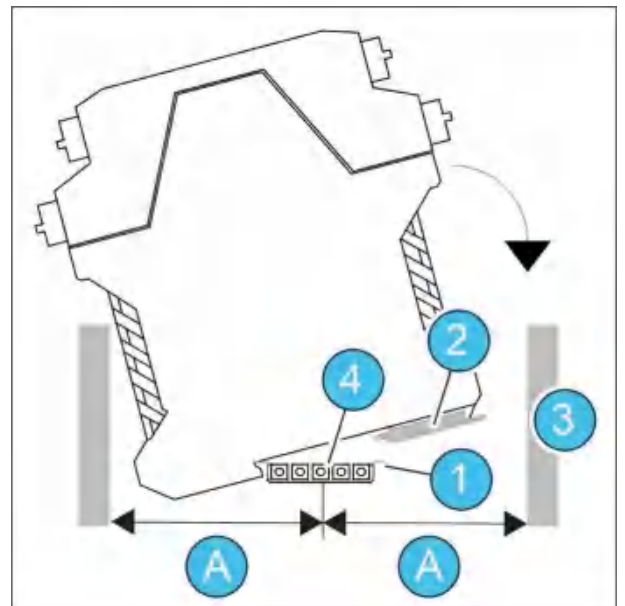

12.2 Removing a module

Procedure

- ▶ Use a screwdriver (1) to move the locking slider away from the module.
- ▶ Move the module upward and remove it from the rail.

